

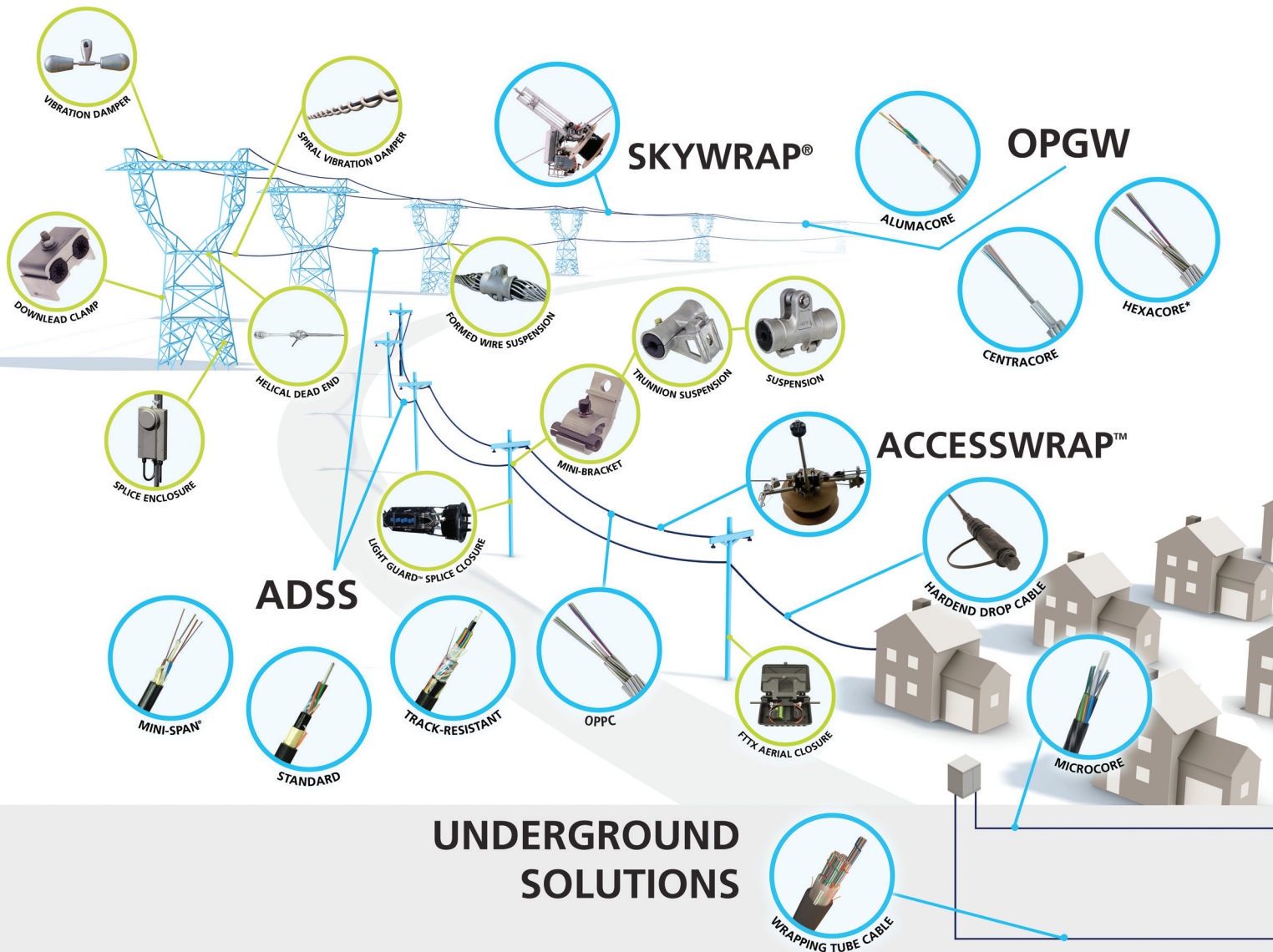

**ENERGY MARKET
SOLUTIONS**

***F* AFL**



UNDERGROUND SOLUTIONS

FIBRE OPTIC SYSTEM OVERVIEW

www.AFLglobal.com

CONTENTS

OPTICAL GROUND WIRE (OPGW)

Introduction to Metallic Aerial Optical Fibre Cables	05
HexaCore OPGW	06
CentraCore OPGW	08
MiniCore OPGW	10
Metallic Aerial Self-Supporting Cable (MASS)	12
Optical Phase Conductor (OPPC)	14

ALL-DIELECTRIC SELF SUPPORTING (ADSS)

Mini-Span® ADSS	17
Flex-Span® ADSS	22
Long Span ADSS	26

UNDERGROUND CABLE

Duct Cables	28
MicroCore®	30
Wrapping Tube Cable (WTC)	32
Flame-Retardant Wrapping Tube Cable (WTC)	34

WRAP SOLUTIONS

SkyWrap®	37
High Voltage SkyWrap®	39
AccessWrap™	40

ACCESSORIES/ HARDWARE

OPGW FITTINGS	43
OPGW Stainless Steel Dome Closure	44
OPGW Aluminium Dome Closure	45
OPGW Accessories	46
Optical phase conductor Insulators	47
OPPC Joint Boxes	49
ADSS Fittings	50
SkyWrap® Ground Wire Hardware	51
SkyWrap® Phase Wire Hardware	52

CONNECTIVITY

Ultra High Density Optical Distribution Frame	55
Am Series Panels	56
Fibre Entry Solutions	57



OPTICAL GROUND WIRE (OPGW)

www.AFLglobal.com

INTRODUCTION TO METALLIC AERIAL OPTICAL FIBRE CABLES

AFL offers a wide variety of metallic aerial optical fibre cables based on stainless steel tube technology. AFL metallic cables are designed to suit a range of applications and customer requirements. The cable designs featured in this catalogue represent a range of capabilities but are by no means an exhaustive list. Many AFL cables are produced to customer specification and we recommend contacting AFL for more information when designing a system to suit.

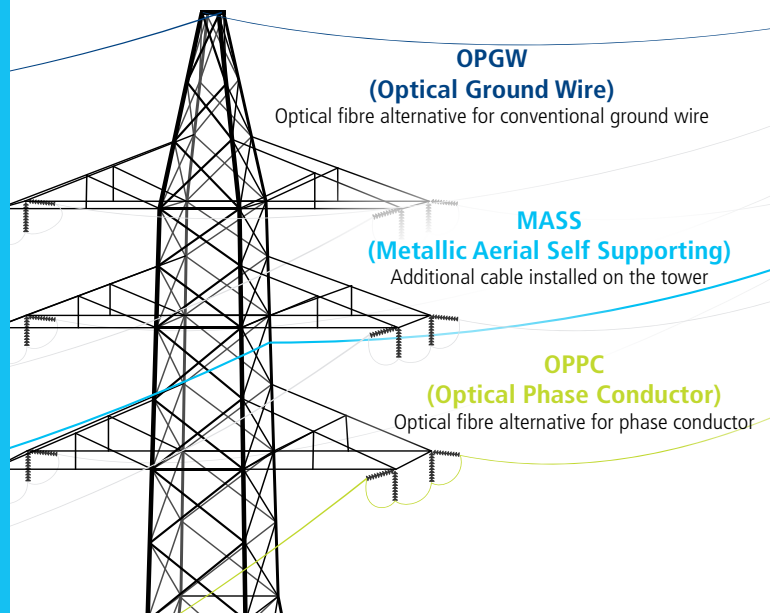

STAINLESS STEEL TUBES

As a manufacturer of stainless steel tubes, AFL is able to provide the best possible tube for the application, filled with thixotropic filling compound and hermetically sealed to provide optimum protection for enclosed fibres. Each tube is eddy-current checked for holes and damage over the entire length.

CABLE DESIGNS

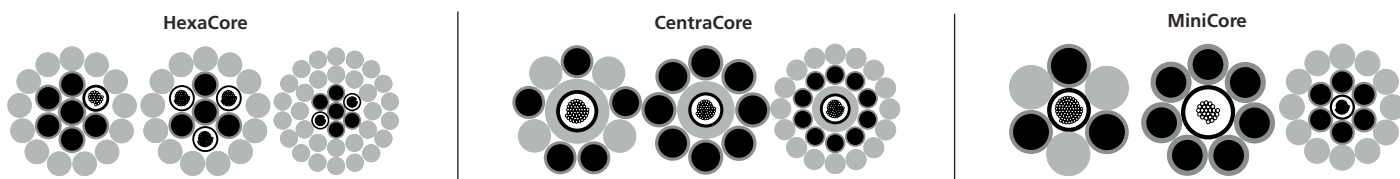

SPECIFICATIONS

Aluminium	EN 60889, IEC 60889
Aluminium Alloy	EN 50183, IEC 60104
Aluminium Clad Steel	EN 61232, IEC 61232
Galvanised Steel	EN 50189, IEC 60888

FIBRES

- ITU-T G.651
- ITU-T G.652 (standard diameter and 200µm)
- ITU-T G.654
- ITU-T G.655
- ITU-T G.657
- Other fibre types can be offered upon request

OPGW TYPE IDENTIFICATION

ASLH	D(S)	bb	1	x	48	SMF	(AL3	/	A20SA	92	/	51	-	13.0)
	Tube Design (S)=Steel loose tube	Armouring one b for each armouring	Number of Steel Tubes		Fibre Count	Fibre Type	Type of Aluminium Alloy		Type of Aluminium Clad Steel	Cross Section of Aluminium Alloy		Cross Section of Aluminium Clad Steel		Nominal Short Current
	(SA)= Aluminium clad steel													

HEXACORE OPGW

HexaCore optical cable houses and protects the optical fibres within gel-filled stainless steel tubes. Aluminium-clad steel and aluminium or aluminium alloy, wires are stranded with the tubes to create a multi-layer design suitable for a variety of applications such as OPGW and OPPC substitution.

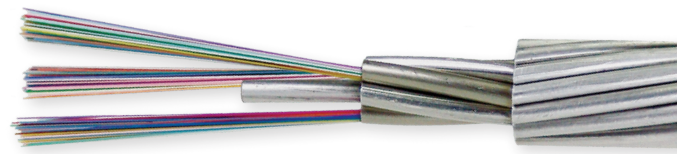

FEATURES

- Optical fibres placed in stranded stainless steel tubes
- Fibre excess length in OPGW $\geq 0,5\%$
- Stainless steel tubes are gel filled for water resistance and shock absorption
- High fibre counts in several steel tubes (144 fibres or more)
- Natural rope-like design very similar to ACSR
- Easy substitution of ACSR ground wires with similar diameter and weight
- No anti-rotation devices required for installation
- Fully metallic design

TEMPERATURE

Operating	- 60°C to + 85°C
Storage	- 60°C to + 85°C
Installation	- 30°C to + 50°C



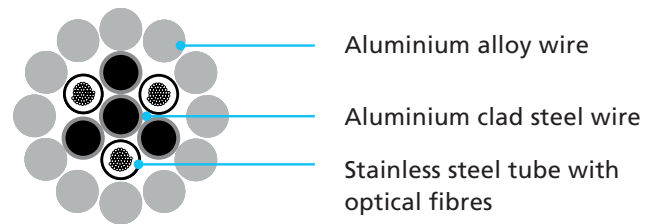

CABLE COMPONENTS

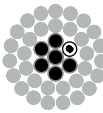

TYPICAL DESIGNS

EQUIVALENT ACSR TO EN 50182	OPGW TYPE	MAXIMUM FIBRE COUNT	CROSS SECTION	DIAMETER (mm)	RTS (kN)	WEIGHT (kg/km)	SHORT CURRENT kA (20-200°C, 1s)
50/30	ASLH-D(S)bb 1 x 24 SMF (AL3/A20SA 52/30 – 7.4)	24		12.1	53.3	365	7.4
95/55	ASLH-D(S)bb 1 x 48 SMF (AL3/A20SA 92/51 – 13.0)	48		16.0	91.5	633	13.0
120/70	ASLH-D(S)bb 2 x 48 SMF (AL3/A20SA 122/51 – 16.3)	96		18.0	97.4	741	16.3
210/50	ASLH-D(S)bbb 2 x 36 SMF (AL3/A20SA212/36-25.0)	72		21.1	108.2	879	25.0
Horse	ASLH-D(S)bb 2 x 24 SMF (AL4 / A20SA 71/30 - 9.5)	60		13.9	61.5	442	9.5

HEXACORE OPGW

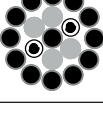
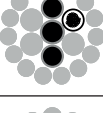
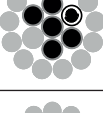
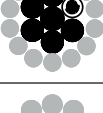
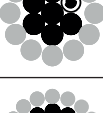
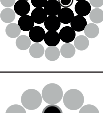
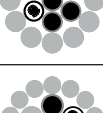
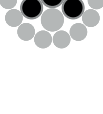
EQUIVALENT ACSR TO EN 50182	OPGW TYPE	MAXIMUM FIBRE COUNT	CROSS SECTION	DIAMETER (mm)	RTS (kN)	WEIGHT (kg/km)	SHORT CURRENT kA (20-200°C, 1s)
Keziah	ASLH-D(S)bbb 1 x 24 SMF (AL3 / A20SA 197/46 - 24.0)	36		20.6	116.4	884	24.0
Dotterel	ASLH-D(S)bb 2 x 48 SMF (AL3 / A20SA 74/42 - 10.5)	96		14.9	75.3	543	10.5
Atle	ASLH-D(S)bb 2 x 48 SMF (AL4 / A20SA 136/57 - 18.1)	120		19.1	110.9	830	18.1
Gondul	ASLH-D(S)bb 2 x 48 SMF (27SA 174 - 13.5)	96		18.2	178.4	1,114	13.5
Sveid	ASLH-D(S)bb 2 x 48 SMF (AL4 / A20SA 55/180 - 17.0)	144		21.0	221.5	1,435	17.0
Sustrong	ASLH-D(S)bb 1 x 48 SMF (AL2 / A20SA 99/26 - 12.2)	48		15.0	64.7	483	12.2
Dorking	ASLH-D(S)bb 1 x 48 SMF (AL3 / A20SA 100/43 - 13.5)	48		16.0	83.5	603	13.5
THYM 107	ASLH-D(S)bb 1 x 48 SMF (AL4 / ST6C 80/51 - 11.0)	48		15.4	96.6	662	11.0
THYM 157	ASLH-D(S)bb 1 x 48 SMF (AL4 / ST6C 133/67 - 17.3)	64		18,9	131,8	948	17,3
THYM 268	ASLH-D(S)bbb 1 x 48 SMF (AL4 / ST6C 149/151 - 22.3)	48		23,0	256,4	1653	22,3
AFL-1,7 70	ASLH-D(S)bb 2 x 24 SMF (AL3 / A20SA 59/25 - 7.9)	48		12,6	49,1	368	7,8
AFL-1,7 95	ASLH-D(S)bb 1 x 48 SMF (AL3 / A20SA 90/35 - 11.8)	48		15,0	69,9	516	11,8

CENTRACORE OPGW

CentraCore optical cable houses and protects the optical fibres within a central gel-filled stainless steel tube inside an aluminium pipe. Aluminium-clad steel and aluminium alloy wires are stranded around the central element in single or multiple layers.



FEATURES

- Optical fibres placed in central aluminium-clad stainless steel tube
- Fibre counts up to 96
- Stainless steel tube is gel filled for water resistance and shock absorption
- Excellent protection of optical fibres
- Excellent crush resistance and high fault current rating capability
- Compact design with good diameter/cross section relation
- Fully metallic design
- Available as single or multi-layer design

TEMPERATURE

Operating	- 40°C to + 85°C
Storage	- 40°C to + 85°C
Installation	- 30°C to + 50°C



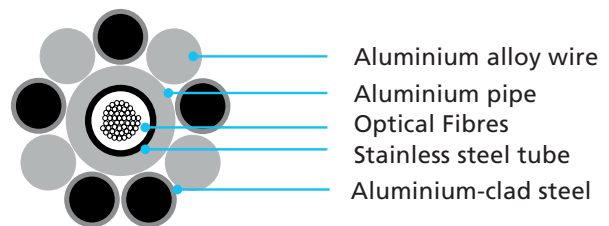





CABLE COMPONENTS

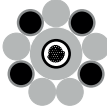

TYPICAL DESIGNS

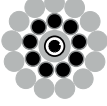
OPGW TYPE	MAXIMUM FIBRE COUNT	CROSS SECTION	DIAMETER (mm)	RTS (kN)	WEIGHT (kg/km)	SHORT CURRENT kA (20-200°C, 1s)
ASLH-D(SA)b 48 SMF (AL3 / A20SA 25/31 - 6.1)	48		11.2	46.5	340	6.1
ASLH-D(SA)b 36 SMF (AL3 / A20SA 33/33 - 7.3)	36		12.0	52.0	376	7.3
ASLH-D(SA)b 48 SMF (AL3 / A20SA 21/42 - 6.8)	48		12.0	60.2	419	6.8
ASLH-D(SA)b 48 SMF (27SA 62 - 7.1)	48		12.1	63.2	461	7.1
ASLH-D(SA)b 96 SMF (A20SA 64 - 5.8)	96		12.3	81.2	515	5.8

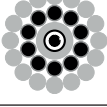
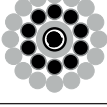
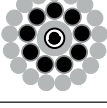
CENTRACORE OPGW

OPGW TYPE	MAXIMUM FIBRE COUNT	CROSS SECTION	DIAMETER (mm)	RTS (kN)	WEIGHT (kg/km)	SHORT CURRENT kA (20-200°C, 1s)
ASLH-D(SA)b 48 SMF (AL4 / A20SA 43/34 - 9.2)	48		13.1	56.9	436	9.2
ASLH-D(SA)b 48 SMF (A20SA 81 - 6.9)	48		13.2	101.3	621	6.9
ASLH-D(SA)bb 48 SMF (AL4 / A20SA 68/43 - 11.4)	48		14.7	78.2	537	11.4
ASLH-D(SA)bb 48 SMF (AL4 / A20SA 79/49 - 13.3)	48		15.8	90.0	617	13.3
ASLH-D(SA)bb 36 SMF (AL3 / A20SA 92/44 - 13.8)	36		16.0	83.3	601	13.8
ASLH-D(SA)bb 96 SMF (AL4 / A20SA 75/50 - 13.2)	96		16.0	87.8	16.0	13.2
ASLH-D(SA)bb 48 SMF (AL4 / A20SA 85/53 - 14.4)	48		16.4	95.2	667	14.4
ASLH-D(SA)bb 72 SMF (AL3 / A20SA 95/59 - 15.9)	72		17.3	103.6	745	15.9
ASLH-D(SA)bb 48 SMF (AL4 / A20SA 97/70 - 16.9)	48		17.9	120.9	819	16.9
ASLH-D(SA)bb 96 SMF (AL4 / A20SA 106/66 - 17.4)	96		18.3	120.2	825	17.4

MINICORE OPGW

MiniCore optical cable houses and protects the optical fibres within a central gel-filled stainless steel tube. Aluminium-clad steel and aluminium alloy wires are stranded around the central element in single or multiple layers.

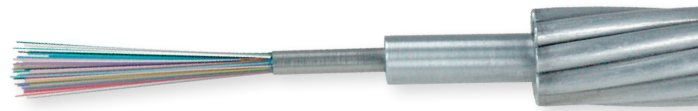

FEATURES

- Optical fibres placed in central stainless steel tube
- Fibre counts up to 96
- Stainless steel tube is gel filled for water resistance and shock absorption
- Compact design with good diameter/cross section relation
- Fully metallic design
- Available as single or multi-layer design

TEMPERATURE

Operating	- 40°C to + 85°C
Storage	- 40°C to + 85°C
Installation	- 30°C to + 50°C

CABLE COMPONENTS

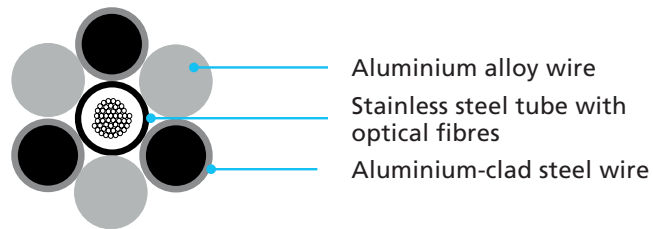



TYPICAL SINGLE LAYER DESIGN

OPGW TYPE	MAXIMUM FIBRE COUNT	CROSS SECTION	DIAMETER (mm)	RTS (kN)	WEIGHT (kg/km)	SHORT CURRENT kA (20-200°C, 1s)
ASLH-D(S)b 24 SMF (27SA 34 - 3.2)	30		8.3	35.3	229	3.3
ASLH-D(S)b 48 SMF (27SA 58 - 5.3)	48		10.5	59.2	374	5.3
ASLH-D(S)b 48 SMF (27SA 75 - 6.9)	72		12.0	77.4	490	6.9
ASLH-D(S)b 48 SMF (AL3 / A20SA 29/29 - 5.3)	48		10.5	43.3	300	5.3
ASLH-D(S)b 48 SMF (AL4 / 27SA 31/31 - 5.8)	48		10.8	40.9	296	5.8
ASLH-D(S)b 48 SMF (AL3 / A20SA 33/33 - 6.0)	60		11.3	49.1	345	6.0

MINICORE OPGW

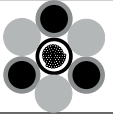
TYPICAL SINGLE LAYER DESIGNS

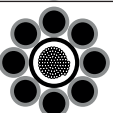
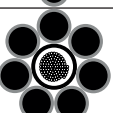
OPGW TYPE	MAXIMUM FIBRE COUNT	CROSS SECTION	DIAMETER (mm)	RTS (kN)	WEIGHT (kg/km)	SHORT CURRENT kA (20-200°C, 1s)
ASLH-D(S)b 72 SMF (AL4 / 27SA 38/38 - 7.2)	72		12.0	50.6	367	7.2
ASLH-D(S)b 96 SMF (AL3 / A20SA 25/25 - 4.5)	96		10.2	38.6	278	4.5
ASLH-D(S)b 96 SMF (27SA 51 - 4.3)	96		10.4	52.4	355	4.3
ASLH-D(S)b 96 SMF (A20SA 67 - 5.2)	96		11.6	81.3	498	5.2

TYPICAL DOUBLE LAYER DESIGNS

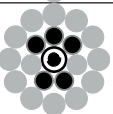
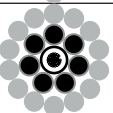
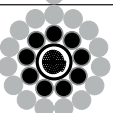
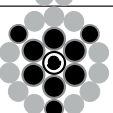
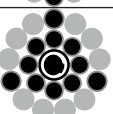
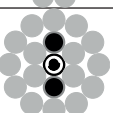
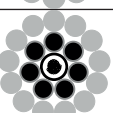
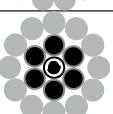
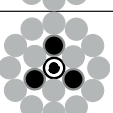
OPGW TYPE	MAXIMUM FIBRE COUNT	CROSS SECTION	DIAMETER (mm)	RTS (kN)	WEIGHT (kg/km)	SHORT CURRENT kA (20-200°C, 1s)
ASLH-D(S)bb 48 SMF (AL3 / A20SA 96/29 - 12.1)	48		15.0	64.8	494	12.1
ASLH-D(S)bb 48 SMF (AL3 / A20SA 120/35 - 15.1)	72		16.7	80.4	614	15.1
ASLH-D(S)bb 48 SMF (AL4 / A20SA 63/39 - 9.2)	48		13.6	70.2	468	9.2
ASLH-D(S)bb 96 SMF (AL4 / A20SA 65/39 - 9.4)	96		14.0	70.8	493	9.4
ASLH-D(S)bb 48 SMF (AL4 / A20SA 78/82 - 13.4)	48		16.8	120.7	806	13.4
ASLH-D(S)bb 96 SMF (AL4 / A20SA 78/76 - 13.0)	96		16.8	120.3	782	13.0
ASLH-D(S)bb 48 SMF (AL4 / A20SA 201/25 - 23.2)	72		20.0	90.7	774	23.2
ASLH-D(S)bb 48 SMF (AL3 / A20SA 92/49 - 12.9)	72		16.0	90.1	632	12.9
ASLH-D(S)bb 48 SMF (AL3 / A20SA 122/61 - 16.9)	48		18.0	109.7	785	16.9
ASLH-D(S)bb 48 SMF (AL3 / A20SA 208/42 - 24.9)	72		21.0	107.9	906	24.9

METALLIC AERIAL SELF-SUPPORTING CABLE (MASS)

Metallic Aerial Self-Supporting (MASS) cable is an alternative solution used for installing optical cable on medium and high voltage power lines. It is typically used when existing phase or ground wire replacement is not possible or uneconomical. MASS cable is a compact, light-weight solution with no electrical function, designed to provide a telecommunications path without interfering with the existing power lines or infrastructure. Its small size helps minimise loading on towers and poles, yet it is completely self-supporting to meet sag and tension requirements. It is typically installed in “under build” applications beneath the live phases.



FEATURES

- Central stainless steel loose tube design
- Typical diameter between 9 and 12 mm
- Fibre counts up to 96
- No voltage limit – suitable for medium and high voltage lines
- Suitable for use on lines without a ground wire
- Convenient means to add fibre where OPGW is already installed
- Deployed in regions with high lightning activity
- Can be installed without an outage
- Small cable size limits additional structural loading
- Suitable for wooden poles with universal attachment
- Aluminium Clad, Aluminium Alloy or Galvanised Steel wire options available depending on mechanical properties required

CABLE COMPONENTS

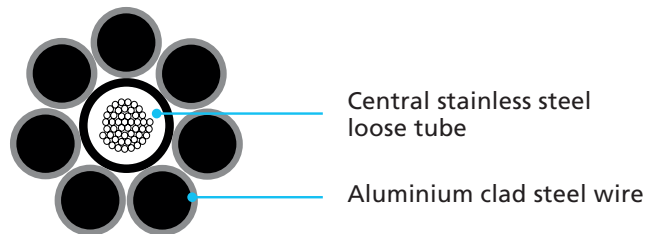

TYPICAL DESIGNS

OPGW TYPE	MAXIMUM FIBRE COUNT	CROSS SECTION	DIAMETER (mm)	RTS (kN)	WEIGHT (kg/km)
ASLH-D(S)b 24 SMF (A20SA 28 - 2.4)	24		7,5	35,4	207
ASLH-D(S)b 24 SMF (A20SA 42 - 3.6)	24		9,0	54,0	303
ASLH-D(S)b 30 SMF (A20SA 34 - 2.9)	30		8,3	43,7	253
ASLH-D(S)b 30 SMF (A20SA 50 - 4.2)	30		9,8	63,4	355

METALLIC AERIAL SELF-SUPPORTING CABLE (MASS)

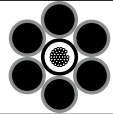
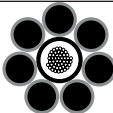
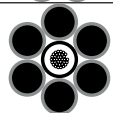
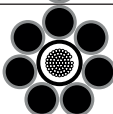
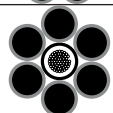
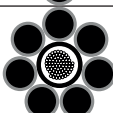
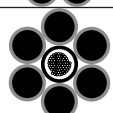
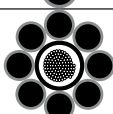
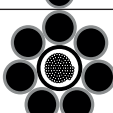
OPGW TYPE	MAXIMUM FIBRE COUNT	CROSS SECTION	DIAMETER (mm)	RTS (kN)	WEIGHT (kg/km)
ASLH-D(S)b 36 SMF (A20SA 37 - 3.1)	36		8,6	47,3	275
ASLH-D(S)b 36 SMF (A20SA 54 - 4.6)	36		10,2	67,8	391
ASLH-D(S)b 48 SMF (A20SA 40 - 3.4)	48		9,0	51,0	298
ASLH-D(S)b 48 SMF (A20SA 58 - 4.9)	48		10,5	69,6	414
ASLH-D(S)b 60 SMF (A20SA 45 - 3.8)	60		9,5	56,8	331
ASLH-D(S)b 60 SMF (A20SA 66 - 5.6)	60		11,3	78,7	475
ASLH-D(S)b 72 SMF (A20SA 49 - 4.2)	72		10,0	63,0	369
ASLH-D(S)b 72 SMF (A20SA 75 - 6.4)	72		12,0	86,7	542
ASLH-D(S)b 96 SMF (A20SA 51 - 4.3)	96		10,3	65,0	388
ASLH-D(S)b 96 SMF (A20SA 67 - 5.7)	96		11,6	81,3	498



OPTICAL PHASE CONDUCTOR (OPPC)

Optical Phase Conductor (OPPC) is used as an alternative telecommunications solution when there is no existing ground wire, meaning Optical Ground Wire (OPGW) is not a viable option. The basic construction is similar to conventional OPGW, only it is designed to simulate the mechanical and electrical characteristics of the phase wire it replaces. Unlike OPGW, where the cable is not carrying continuous current, OPPC is energised along high voltage power lines. Therefore it requires specially adapted splice boxes and insulators to accommodate the live line conditions.

AFL can design a cable to accommodate your precise application. To do so, we need the properties of the phase conductor you are seeking to replace. With that, we can do the rest.



FEATURES

- Engineered to match existing conductors
- Available in fibre counts up to 144
- Distribution or transmission – from 36 to 245 kV
- Suitable for any type of optical fibre, single-mode or multi-mode
- Designed to match electrical properties of conductor it replaces
- Uses standard fibre optic dead ends and suspension grips

CABLE COMPONENTS

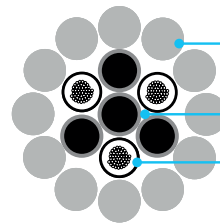

Aluminium alloy wire

Aluminium clad steel wire

Stainless steel tube with optical fibres







OPPC HARDWARE

A full range of insulators and joint boxes are available to suit customer specifications. Please refer to the Accessories section of this catalogue

OPTICAL PHASE CONDUCTOR

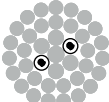
TYPICAL DESIGNS

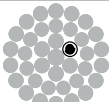
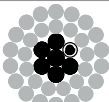
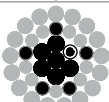
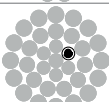
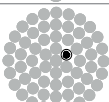
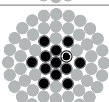
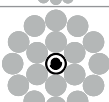
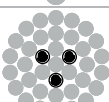
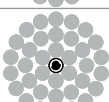
EQUIVALENT ACSR TO EN 50182	OPGW TYPE	MAXIMUM FIBRE COUNT	CROSS SECTION	DIAMETER (mm)	RTS (kN)	WEIGHT (kg/km)	CURRENT CAPACITY (A) (35-80°C, 0,6m/s)
70/12	ASLH-D(S)bb 1 x 24 SMF (AL1 / A20SA 66/15 - 8.1)	24		12.1	30.1	307	301
95/15	ASLH-D(S)bb 2 x 24 SMF (AL1 / A20SA 90/12 - 10.4)	60		13.9	29.5	370	357
120/20	ASLH-D(S)bb 1 x 48 SMF (AL1 / A20SA 114/25 - 13.8)	48		15.8	49.6	519	422
ASTER 228	ASLH-D(S)bbb 2 x 24 SMF (AL4 226 - 23.8)	72		20.2	73.6	676	561
PASTEL 228	ASLH-D(S)bbb 1 x 48 SMF (AL4 / ST6C 180/52 - 21.2)	48		20.2	121.6	930	502
ASTER 288	ASLH-D(S)bbb 1 x 48 SMF (AL4 288 - 30.3)	48		22.4	93.5	833	641
PASTEL 288	ASLH-D(S)bbb 1 x 48 SMF (AL4 / ST6C 237/51 - 27.2)	48		22.4	155.1	1097	581
PASTEL 412	ASLH-D(S)bbb 1 x 48 SMF (AL4 / A20SA 288/117 - 37.3)	64		26.5	224.3	1660	726
ASTER 366	ASLH-D(S)bbb 1 x 48 SMF (AL4 374 - 39.3)	48		25.5	118.2	1069	758
ASTER 570	ASLH-D(S)bbbb 1 x 48 SMF (AL4 578 - 60.8)	48		31.6	187.7	1650	988
PETUNIA 612	ASLH-D(S)bbbb 1 x 48 SMF (AL4 / A20SA 489/123 - 58.8)	64		32.5	309.1	2247	944
ELM	ASLH-D(S)bb 48 SMF (AL3 210 - 22.6)	60		19.3	61.8	628	544
Poplar	ASLH-D(S)bbb 3 x 32 SMF (AL5 240 - 25.9)	96		21.0	70.9	731	599
UPAS	ASLH-D(S)bbb 48 SMF (AL3 366 - 39.5)	48		25.2	108.1	1063	771

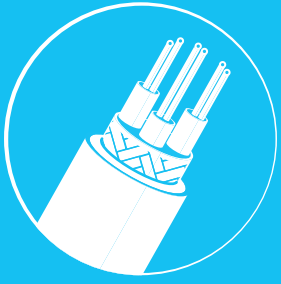

ALL-DIELECTRIC SELF SUPPORTING (ADSS)

www.AFLglobal.com

MINI-SPAN® ADSS

AFL Mini-Span All-Dielectric Self-Supporting (ADSS) cable is designed for outside plant aerial and duct applications in local and campus network loop architectures. From pole-to-build to town-to-town installations, the Mini-Span cabling system, which includes cables, suspension, dead end and termination enclosures, offers a comprehensive transmission circuit infrastructure with proven, high-reliability performance. As the ADSS cabling concept implies, a separate messenger support wire hanging system is not required, greatly reducing installation time and improving upfront and maintenance labour costs.

Mini-Span includes fibre counts up to 96 optical fibres and any type or combination of single-mode and laser-optimised multi-mode fibres with the cable. Pole-to-Pole span lengths range from 15 metres to over 300 metres.

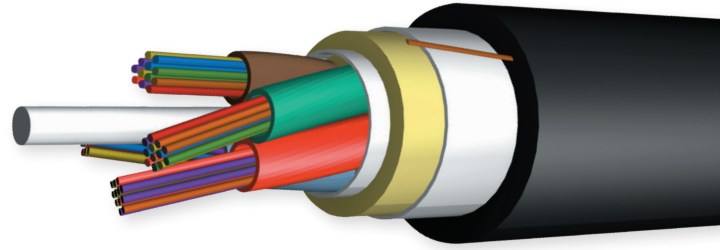

TEMPERATURE

Operating	- 40°C to + 70°C
Storage	- 50°C to + 70°C
Installation	- 30°C to + 70°C

INSTALLATION INFORMATION

CABLE	NESC SPANS (@ 1.5% INITIAL SAG) METRES			MAX. SAGGING TENSION N	MAX. LOADING OPERATING TENSION N	MIN. BENDING RADIUS (DYNAMIC) CM	MIN. BENDING RADIUS (STATIC) CM
	LIGHT	MEDIUM	HEAVY				
Mini-Span 383	137	91	55	814	1,785	20	10

CABLE	NESC SPANS (@ 1% INITIAL SAG) METRES			MAX. SAGGING TENSION N	MAX. LOADING OPERATING TENSION N	MIN. BENDING RADIUS CM	MIN. BENDING RADIUS (STATIC) CM
	LIGHT	MEDIUM	HEAVY				
Mini-Span 424	183	134	84	1,886	3,145	22	11
Mini-Span 535	320	259	175	5,809	7,936	27	14

OPTICAL INFORMATION

CABLE	MAXIMUM ATTENUATION (db/km)			BANDWIDTH (MHz•km)		
	SINGLE-MODE (1310 nm/1550 nm)	MULTI-MODE *62.5/125 µm (850 nm/1300 nm)	MULTI-MODE 50/125 µm (850 nm/1300 nm)	SINGLE-MODE (1310 nm/1550 nm)	MULTI-MODE *62.5/125 µm (850 nm/1300 nm)	MULTI-MODE 50/125 µm (850 nm/1300 nm)
Mini-Span 383	0.35/0.25	3.5/1.2	2.9/0.9	n/a	200/600	500/500
Mini-Span 424						
Mini-Span 535						

* All 62.5/125 µm multi-mode ADSS cable transmission performances meet or exceed FDDI requirements. Premium transmission performance fibres available on request.

MINI-SPAN® ADSS

MECHANICAL DATA

CABLE	FIBRE COUNT	NOMINAL DIAMETER	NOMINAL WEIGHT	MAXIMUM LENGTHS*	
				SINGLE-MODE	MULTI-MODE
		MM	KG/KM	METRES	METRES
Mini-Span 383	2-48	9.7	72	10,000	8,000
Mini-Span 424	2-60	10.8	84	10,000	8,000
Mini-Span 535	2-96	13.6	148	10,000	8,000

* Longer lengths may be available upon request.

ORDERING INFORMATION

CABLE	FIBRE COUNT	FIBRES PER TUBE	NUMBER OF TUBES / FIBRES	AFL NO.		
				SINGLE-MODE	MULTI-MODE 62.5/125	MULTI-MODE 50/125
Mini-Span 383	6	6	1 w/6 (3 fillers)	AE0069C420AA0	AE0066C420AA0	AE0065C420AA0
	12	12	1 w/12 (3 fillers)	AE0129C420AA0	AE0126C420AA0	AE0125C420AA0
	18	12	1 w/12, 1 w/6 (2 fillers)	AE0189C420AA0	AE0186C420AA0	AE0185C420AA0
	24	12	2 w/12 (2 fillers)	AE0249C420AA0	AE0246C420AA0	AE0245C420AA0
	30	12	2 w/12, 1 w/6 (1 filler)	AE0309C420AA0	AE0306C420AA0	AE0305C420AA0
	36	12	3 w/12 (1 filler)	AE0369C420AA0	AE0366C420AA0	AE0365C420AA0
	48	12	4 w/12	AE0489C420AA0	AE0486C420AA0	AE0485C420AA0
Mini-Span 424	6	6	1 w/6 (4 fillers)	AE0069C520AA4	AE0066C520AA4	AE0065C520AA4
	12	12	1 w/12 (4 fillers)	AE0129C520AA4	AE0126C520AA4	AE0125C520AA4
	18	12	1 w/12, 1 w/6 (3 fillers)	AE0189C520AA4	AE0186C520AA4	AE0185C520AA4
	24	12	2 w/12 (3 fillers)	AE0249C520AA4	AE0246C520AA4	AE0245C520AA4
	30	12	2 w/12, 1 w/6 (2 fillers)	AE0309C520AA4	AE0306C520AA4	AE0305C520AA4
	36	12	3 w/12 (2 fillers)	AE0369C520AA4	AE0366C520AA4	AE0365C520AA4
	48	12	4 w/12 (1 filler)	AE0489C520AA4	AE0486C520AA4	AE0485C520AA4
Mini-Span 535	60	12	5 w/12 (no fillers)	AE0609C520AA4	AE0606C520AA4	AE0605C520AA4
	6	6	1 w/6 (7 fillers)	AE0069C820EA7	AE0066C820EA7	AE0065C820EA7
	12	12	1 w/12 (7 fillers)	AE0129C820EA7	AE0126C820EA7	AE0125C820EA7
	18	12	1 w/12, 1 w/6 (6 fillers)	AE0189C820EA7	AE0186C820EA7	AE0185C820EA7
	24	12	2 w/12 (6 fillers)	AE0249C820EA7	AE0246C820EA7	AE0245C820EA7
	30	12	2 w/12, 1 w/6 (5 fillers)	AE0309C820EA7	AE0306C820EA7	AE0305C820EA7
	36	12	3 w/12 (5 fillers)	AE0369C820EA7	AE0366C820EA7	AE0365C820EA7
	48	12	4 w/12 (4 fillers)	AE0489C820EA7	AE0486C820EA7	AE0485C820EA7
	60	12	5 w/12 (3 fillers)	AE0609C820EA7	AE0606C820EA7	AE0605C820EA7
	72	12	6 w/12 (2 fillers)	AE0729C820EA7	AE0726C820EA7	AE0725C820EA7
	84	12	7 w/12 (1 filler)	AE0849C820EA7	AE0846C820EA7	AE0845C820EA7
96	12	8 w/12 (no fillers)	AE0969C820EA7	AE0966C820EA7	AE0965C820EA7	

Contact customer service for price and availability. Non-zero dispersion-shifted fibres are also available.

MINI-SPAN® ADSS

SAG AND TENSION INFORMATION

CABLE	SPAN METRES	INITIAL SAG %	INITIAL TENSION N	NESC LIGHT LOADING		NESC MEDIUM LOADING		NESC HEAVY LOADING	
				SAG	TENSION	SAG	TENSION	SAG	TENSION
				%	N	%	N	%	N
MINI-SPAN 383	15	1.5	89	0.5	337	2.2	482	3.2	717
	23	1.5	133	0.5	457	2.4	648	3.6	956
	30	1.5	182	0.6	568	2.6	798	4.0	1,171
	38	1.5	227	0.6	671	2.8	938	4.2	1,370
	46	1.5	271	0.6	768	2.9	1,070	4.5	1,558
	53	1.5	316	0.6	862	3.0	1,196	4.7	1,736
	61	1.5	360	0.7	952	3.2	1,317	—	—
	69	1.5	405	0.7	1,040	3.3	1,434	—	—
	76	1.5	449	0.7	1,125	3.4	1,547	—	—
	84	1.5	498	0.7	1,209	3.5	1,657	—	—
	91	1.5	543	0.7	1,290	3.5	1,765	—	—
	99	1.5	587	0.8	1,370	—	—	—	—
	107	1.5	632	0.8	1,448	—	—	—	—
	114	1.5	676	0.8	1,525	—	—	—	—
	122	1.5	721	0.8	1,601	—	—	—	—
	130	1.5	765	0.8	1,676	—	—	—	—
137	1.5	814	0.8	1,750	—	—	—	—	

CABLE COMPONENTS

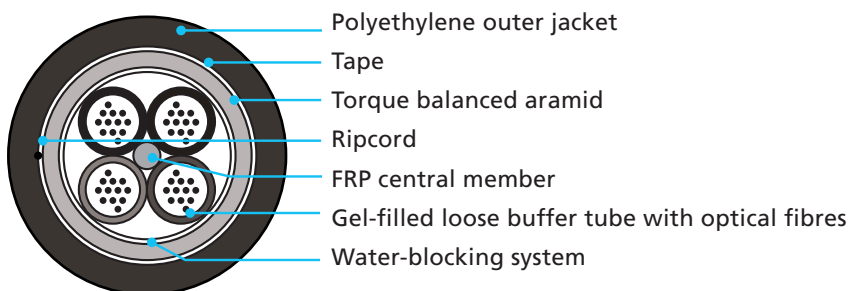

4 POSITION 323 OR 383

MINI-SPAN® ADSS

SAG AND TENSION INFORMATION

CABLE	SPAN METRES	INITIAL SAG %	INITIAL TENSION N	NESC LIGHT LOADING		NESC MEDIUM LOADING		NESC HEAVY LOADING	
				SAG	TENSION	SAG	TENSION	SAG	TENSION
				%	N	%	N	%	N
MINI-SPAN 424	15	1.0	156	0.4	463	1.7	632	2.6	921
	23	1.0	236	0.4	632	1.9	850	3.0	1,223
	30	1.0	316	0.5	783	2.1	1,095	3.2	1,499
	38	1.0	391	0.5	925	2.2	1,228	3.4	1,757
	46	1.0	472	0.5	1,059	2.4	1,401	3.6	1,997
	53	1.0	552	0.5	1,192	2.5	1,570	3.8	2,229
	61	1.0	627	0.6	1,317	2.6	1,730	4.0	2,447
	69	1.0	707	0.6	1,441	2.7	1,886	4.1	2,660
	76	1.0	787	0.6	1,561	2.7	2,037	4.2	2,869
	84	1.0	863	0.6	1,681	2.8	2,184	4.3	3,069
	91	1.0	943	0.6	1,737	2.8	2,331	—	—
	99	1.0	1,023	0.6	1,908	2.9	2,473	—	—
	107	1.0	1,099	0.6	2,024	3.0	2,611	—	—
	114	1.0	1,179	0.6	2,131	3.0	2,749	—	—
	122	1.0	1,259	0.6	2,242	3.1	2,882	—	—
	130	1.0	1,334	0.7	2,349	3.1	3,016	—	—
	137	1.0	1,415	0.7	2,455	3.2	3,145	—	—
	145	1.0	1,495	0.7	2,562	—	—	—	—
	152	1.0	1,570	0.7	2,669	—	—	—	—
	160	1.0	1,650	0.7	2,771	—	—	—	—
168	1.0	1,730	0.7	2,874	—	—	—	—	
175	1.0	1,806	0.7	2,976	—	—	—	—	
183	1.0	1,886	0.7	3,078	—	—	—	—	

CABLE COMPONENTS

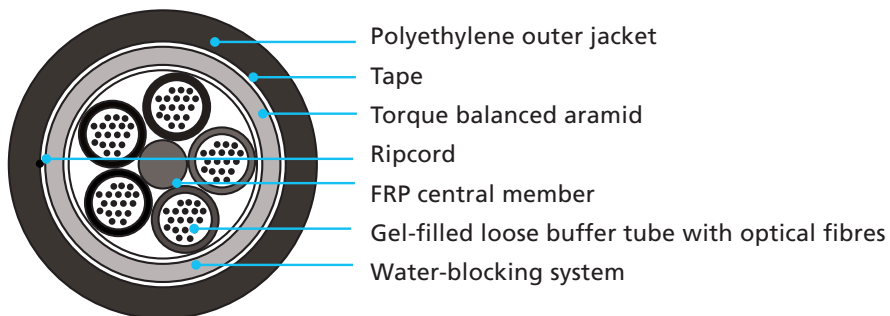

5 POSITION 424

MINI-SPAN® ADSS

SAG AND TENSION INFORMATION

CABLE	SPAN METRES	INITIAL SAG %	INITIAL TENSION N	NESC LIGHT LOADING		NESC MEDIUM LOADING		NESC HEAVY LOADING	
				SAG	TENSION	SAG	TENSION	SAG	TENSION
				%	N	%	N	%	N
MINI-SPAN 535	15	1	276	0.4	713	1.5	918	2.1	1,319
	30	1	552	0.5	1,220	1.7	1,542	2.5	2,176
	46	1	832	0.6	1,670	1.9	2,087	2.8	2,915
	61	1	1,108	0.6	2,088	2.1	2,590	3.1	3,588
	76	1	1,383	0.6	2,486	2.2	3,063	3.3	4,217
	91	1	1,659	0.6	2,868	2.3	3,515	3.4	4,813
	107	1	1,935	0.7	3,239	2.4	3,951	3.6	5,384
	122	1	2,211	0.7	3,601	2.5	4,374	3.7	5,935
	137	1	2,491	0.7	3,956	2.5	4,785	3.8	6,469
	152	1	2,767	0.7	4,304	2.6	5,188	3.9	6,988
	168	1	3,043	0.7	4,647	2.7	5,583	4.0	7,495
	175	1	3,180	0.7	4,817	2.7	5,778	4.1	7,745
	183	1	3,318	0.7	4,985	2.7	5,971	—	—
	198	1	3,594	0.8	5,320	2.8	6,353	—	—
	213	1	3,870	0.8	5,650	2.8	6,730	—	—
	229	1	4,150	0.8	5,978	2.8	7,102	—	—
	244	1	4,426	0.8	6,303	2.9	7,469	—	—
	259	1	4,702	0.8	6,625	2.9	7,833	—	—
	274	1	4,978	0.8	6,945	—	—	—	—
	290	1	5,253	0.8	7,263	—	—	—	—
305	1	5,529	0.8	7,579	—	—	—	—	
320	1	5,809	0.8	7,894	—	—	—	—	

CABLE COMPONENTS

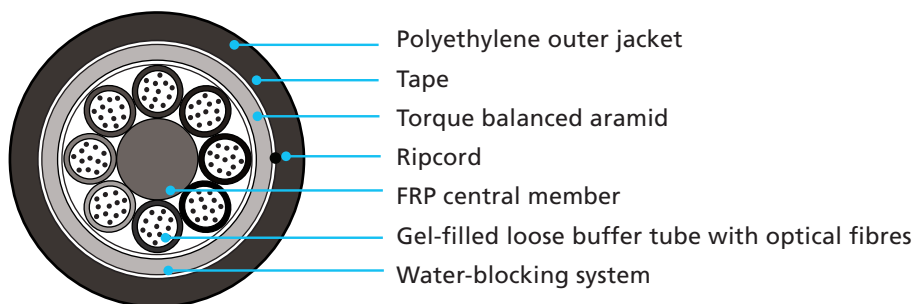

8 POSITION 535

REEL INFORMATION

REEL SPECIFICATIONS	REEL A	REEL B	REEL C	REEL D	REEL E
ITEM	CM	CM	CM	CM	CM
Reel Height	106.7	147.3	167.6	182.8	213.4
Reel Width Outside	91.4	96.5	106.7	106.7	101.6
Reel Width Inside	81.6	81.3	91.4	91.4	86.4
Drum Diameter	58.7	71.1	91.4	91.4	88.9
Arbor Hole Diameter	7.9	7.9	7.9	7.9	7.9
Reel Weight with Lagging	82 kg	191 kg	311 kg	320 kg	431 kg
MAXIMUM CABLE LENGTH (FEET/METRES)					
Mini-Span 383	3,300 m	7,700 m	10,000 m	—	—
Mini-Span 424	2,700 m	6,200 m	8,000 m	10,000 m	—
Mini-Span 535	1,675 m	3,900 m	5,250 m	6,920 m	10,000 m

AFL provides ADSS cable on several standard sizes of non-returnable wooden reels. Non-standard reel sizes are available on request.

FLEX-SPAN® ADSS

Flex-Span ADSS expands on AFL's single jacket ADSS portfolio. Flex-Span designs are optimised for a broader combination of fibre counts and span lengths, providing ADSS system designers more flexibility in their product selection. As its name indicates, there is no support or messenger wire required, so installation is achieved in a single pass.

Flex-Span ADSS includes fibre counts up to 144 optical fibres and any type or combination of single-mode or multi-mode fibres within the cable. Pole-to-pole span lengths range from 15 metres to over 300 metres.

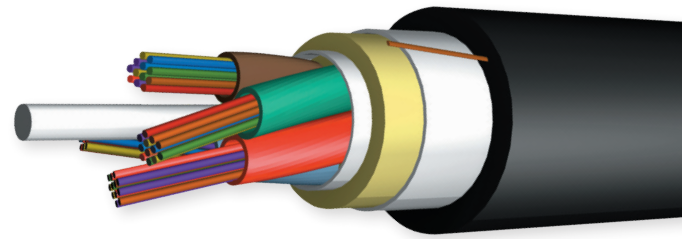

FEATURES

- Suitable for use on distribution lines
- Gel-filled buffer tubes are S-Z stranded for easy mid-span access
- Cable is water-blocked using dry core technology, therefore no messy flooding compounds
- Design details listed below for span lengths up to 457m and fibre counts up to 144
- Requires the use of formed wire dead ends

TYPICAL MAXIMUM LENGTHS

CABLE DIAMETER	REEL CAPACITY (METRES)
21.6 mm	7,000

TEMPERATURE

Operating	- 40°C to + 85°C
Storage	- 40°C to + 85°C
Installation	- 30°C to + 50°C

CABLE COMPONENTS

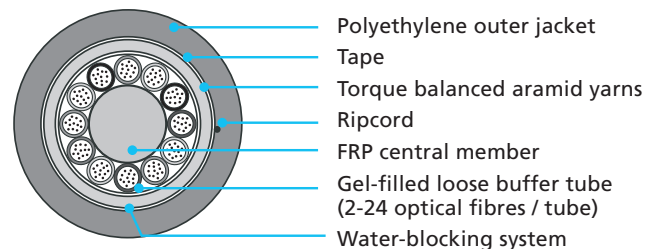

OPTICAL INFORMATION

FIBRE TYPE	MAXIMUM ATTENUATION (dB/km)				OVERFILL LAUNCH MIN. BANDWIDTH (MHz•km)		GIGABIT ETHERNET MINIMUM LINK DISTANCE (metres)	
	850 nm	1300 nm	1310 nm	1550 nm	850 nm	1300 nm	850 nm	1300 nm
(6) 62.5/125 GIGA-Link™ 300	3.5	1.2	N/A	N/A	200	600	300	550
(8) 62.5/125 GIGA-Link™ 1000	3.5	1.2	N/A	N/A	350	600	500	1000
(5) 50/125 GIGA-Link™ 600	2.9	0.9	N/A	N/A	500	500	600	600
(7) 50/125 GIGA-Link™ 2000	2.9	0.9	N/A	N/A	500	800	750	2000
(L) 50 Laser-Link™ 300	2.9	0.9	N/A	N/A	1500	500	900	550
(9) Single-mode	N/A	N/A	0.35	0.25	N/A	N/A	N/A	5000
(Q) Non-zero Dispersion-shifted Single-mode	N/A	N/A	N/A	0.25	N/A	N/A	N/A	N/A
(K) SM Futureguide SR-15e Bend Insensitive	N/A	N/A	0.35	0.25	N/A	N/A	N/A	5000

Gigabit Ethernet Minimum Link Distances are based on "bandwidth"/modal dispersion constraints. Actual link distances may be constrained by attenuation, depending on specific loss budget.

FLEX-SPAN® ADSS

REEL INFORMATION

ITEM	REEL A	REEL B	REEL C	REEL D	REEL E
	CM	CM	CM	CM	CM
Reel Height	106.7	147.3	167.6	167.6	213.4
Reel Width Outside	91.4	96.5	106.7	106.7	101.6
Reel Width Inside	81.6	81.3	91.4	91.4	86.4
Drum Diameter	58.7	71.1	91.4	91.4	88.9
Arbor Hole Diameter	7.9	7.9	7.9	7.9	7.9
Reel Weight with Lagging	82 kg	191 kg	311 kg	311 kg	431 kg

AFL provides ADSS cable on several standard sizes of non-returnable wooden reels. Non-standard reel sizes are available upon request.

NESC LIGHT @ 1.5% INSTALLATION SAG							
SPAN METRES	AFL NO.	WEIGHT KG/KM	DIAMETER MM	MRCL N	INITIAL TENSION ¹		
					UNLOADED N	LOADED SAG %	N
12 FIBRES							
160	AE012*C520A08	84	10.8	2398	1104	0.8	2318
183	AE012*C520AA0	84	10.8	2661	1264	0.8	2634
213	AE012*C520AA5	84	10.8	3320	1482	0.8	3124
244	AE012*C520E08	88	11	3600	1758	0.8	3591
282	AE012*C520EA1	88	11	4445	2034	0.8	4214
320	AE012*C520EA2	88	11	4726	2309	0.8	4712
335	AE012*C520EA4	88	11	5291	2421	0.8	5015
24 FIBRES							
160	AE024*C520A08	86	10.8	2398	1121	0.8	2327
183	AE024*C520AA0	86	10.8	2661	1286	0.8	2643
213	AE024*C520AA5	86	10.8	3320	1504	0.8	3137
244	AE024*C520EA0	90	11	4165	1789	0.8	3729
282	AE024*C520EA1	90	11	4445	2065	0.8	4232
308	AE024*C520EA2	90	11	4726	2256	0.8	4592
335	AE024*C520EA4	90	11	5291	2461	0.8	5033
48 FIBRES							
160	AE048*C520A08	89	10.8	2398	1161	0.9	2350
183	AE048*C520AA1	89	10.8	2794	1326	0.9	2697
213	AE048*C520AA5	89	10.8	3320	1553	0.8	3164
244	AE048*C520EA0	93	11	4165	1842	0.8	3760
282	AE048*C520EA1	93	11	4445	2131	0.9	4263
314	AE048*C520EA2	93	11	4726	2376	0.9	4699
335	AE048*C520EA4	93	11	5291	2536	0.9	5073
72 FIBRES							
221	AE072*C620A08	112	11.8	3800	2020	0.9	3702
244	AE072*C620AA0	112	11.8	4063	2229	0.9	4054
267	AE072*C620AA3	112	11.8	4459	2438	0.9	4441
297	AE072*C620AA7	112	11.8	4984	2719	0.9	4953
328	AE072*C620EA0	112	11.8	5562	2999	0.9	5473
96 FIBRES							
282	AE096*C820A08	148	13.4	5767	3422	1	5651
305	AE096*C820AA1	149	13.4	6159	3702	1	6096
144 FIBRES							
221	AE144*O620A08	126	12.3	4061	2278	1.0	4031
259	AE144*O620AA4	128	12.4	4787	2709	1.0	4770
320	AE144*O620EA1	130	12.5	5954	3399	1.0	5948

¹ Initial tension indicates tension before 10 year creep.

Note: Diameter and weight subject to change without notice

* Fibre Types – Replace asterisk (*) in AFL number with number corresponding to desired fibre type below.

- 5 = 50/125 µm multi-mode GIGA-Link™ 600
- 7 = 50/125 µm multi-mode GIGA-Link™ 2000
- 6 = 62.5/125 µm multi-mode GIGA-Link™ 300
- 8 = 62.5/125 µm multi-mode GIGA-Link™ 1000
- L = 50/125 µm multi-mode Laser-Link™ 300
- 9 = Single-mode
- K = SM Futureguide SR-15e Bend Insensitive
- Q = Non-zero dispersion-shifted single-mode

FLEX-SPAN® ADSS

NESC MEDIUM @ 1.5% INSTALLATION SAG							
SPAN METRES	AFL NO.	WEIGHT KG/KM	DIAMETER MM	MRCL N	INITIAL TENSION ¹		
					UNLOADED N	LOADED SAG %	N
12 FIBRES							
114	AE012*C520A08	84	10.8	2398	792	3.5	2367
122	AE012*C520AA0	84	10.8	2661	841	3.5	2550
152	AE012*C520AA5	84	10.8	3320	1059	3.5	3191
168	AE012*C520E08	88	11	3600	1210	3.5	3529
198	AE012*C520EA1	88	11	4445	1428	3.4	4223
213	AE012*C520EA2	88	11	4726	1540	3.5	4530
244	AE012*C520EA4	88	11	5291	1762	3.5	5148
24 FIBRES							
114	AE024*C520A08	86	10.8	2398	805	3.5	2372
122	AE024*C520AA0	86	10.8	2661	854	3.5	2559
152	AE024*C520AA5	86	10.8	3320	1077	3.5	3199
190	AE024*C520EA0	90	11	4165	1397	3.5	4040
198	AE024*C520EA1	90	11	4445	1451	3.4	4232
213	AE024*C520EA2	90	11	4726	1566	3.5	4543
244	AE024*C520EA4	90	11	5291	1789	3.5	5162
48 FIBRES							
114	AE048*C520A08	89	10.8	2398	832	3.5	2385
130	AE048*C520AA1	89	10.8	2794	939	3.5	2723
152	AE048*C520AA5	89	10.8	3320	1112	3.5	3217
190	AE048*C520EA0	93	11	4165	1442	3.5	4063
198	AE048*C520EA1	93	11	4445	1500	3.4	4258
213	AE048*C520EA2	93	11	4726	1615	3.5	4570
244	AE048*C520EA4	93	11	5291	1847	3.5	5193
72 FIBRES							
160	AE072*C620A08	112	11.8	3800	1460	3.4	3671
175	AE072*C620AA0	112	11.8	4063	1602	3.4	4000
190	AE072*C620AA3	112	11.8	4459	1740	3.4	4356
216	AE072*C620AA7	112	11.8	4984	1980	3.5	4930
244	AE072*C620EA0	112	11.8	5562	2229	3.5	5540
96 FIBRES							
221	AE096*C820A08	148	13.4	5767	2683	3.4	5705
236	AE096*C820AA1	149	13.4	6159	2870	3.4	6096
144 FIBRES							
160	AE144*O620A08	126	12.3	4061	1646	3.3	3947
190	AE144*O620AA4	128	12.4	4787	1993	3.3	4711
236	AE144*O620EA1	130	12.5	5954	2509	3.3	5878

1 Initial tension indicates tension before 10 year creep.

Note: Diameter and weight subject to change without notice

* Fibre Types – Replace asterisk (*) in AFL number with number corresponding to desired fibre type below.

- 5 = 50/125 µm multi-mode GIGA-Link™ 600
- 7 = 50/125 µm multi-mode GIGA-Link™ 2000
- 6 = 62.5/125 µm multi-mode GIGA-Link™ 300
- 8 = 62.5/125 µm multi-mode GIGA-Link™ 1000
- L = 50/125 µm multi-mode Laser-Link™ 300
- 9 = Single-mode
- K = SM Futureguide SR-15e Bend Insensitive
- Q = Non-zero dispersion-shifted single-mode

FLEX-SPAN® ADSS

NESC HEAVY @ 1.5% INSTALLATION SAG							
SPAN METRES	AFL NO.	WEIGHT KG/KM	DIAMETER MM	MRCL N	INITIAL TENSION ¹		
					UNLOADED N	LOADED SAG % N	
12 FIBRES							
61	AE012*C520A08	84	10.8	2398	423	4.5	2158
76	AE012*C520AA0	84	10.8	2661	525	4.6	2603
91	AE012*C520AA5	84	10.8	3320	636	4.6	3159
99	AE012*C520E08	88	11	3600	712	4.6	3449
122	AE012*C520EA1	88	11	4445	881	4.6	4250
137	AE012*C520EA2	88	11	4726	988	4.7	4703
152	AE012*C520EA4	88	11	5291	1099	4.7	5237
24 FIBRES							
61	AE024*C520A08	86	10.8	2398	427	4.5	2158
76	AE024*C520AA0	86	10.8	2661	534	4.6	2608
91	AE024*C520AA5	86	10.8	3320	645	4.6	3168
114	AE024*C520EA0	90	11	4165	837	4.6	3991
122	AE024*C520EA1	90	11	4445	894	4.6	4258
137	AE024*C520EA2	90	11	4726	975	4.7	4690
152	AE024*C520EA4	90	11	5291	1117	4.7	5246
48 FIBRES							
61	AE048*C520A08	89	10.8	2398	441	4.5	2167
76	AE048*C520AA1	89	10.8	2794	552	4.6	2652
91	AE048*C520AA5	89	10.8	3320	667	4.6	3177
114	AE048*C520EA0	93	11	4165	863	4.6	4005
122	AE048*C520EA1	93	11	4445	921	4.6	4272
137	AE048*C520EA2	93	11	4726	1037	4.7	4726
152	AE048*C520EA4	93	11	5291	1153	4.7	5264
72 FIBRES							
91	AE072*C620A08	112	11.8	3800	837	4.4	3444
107	AE072*C620AA0	112	11.8	4063	975	4.6	3916
122	AE072*C620AA3	112	11.8	4459	1112	4.6	4428
137	AE072*C620AA7	112	11.8	4984	1255	4.6	4970
152	AE072*C620EA0	112	11.8	5562	1393	4.6	5531
96 FIBRES							
122	AE096*C820A08	148	13.4	5767	1482	4.3	5073
152	AE096*C820AA1	149	13.4	6159	1851	4.5	6070
144 FIBRES							
91	AE144*O620A08	126	12.3	4061	943	4.3	3675
122	AE144*O620AA4	128	12.4	4787	1277	4.4	4748
152	AE144*O620EA1	130	12.5	5954	1619	4.4	5944

1 Initial tension indicates tension before 10 year creep.

Note: Diameter and weight subject to change without notice

* Fibre Types – Replace asterisk (*) in AFL number with number corresponding to desired fibre type below.

- 5 = 50/125 µm multi-mode GIGA-Link™ 600
- 7 = 50/125 µm multi-mode GIGA-Link™ 2000
- 6 = 62.5/125 µm multi-mode GIGA-Link™ 300
- 8 = 62.5/125 µm multi-mode GIGA-Link™ 1000
- L = 50/125 µm multi-mode Laser-Link™ 300
- 9 = Single-mode
- K = SM Futureguide SR-15e Bend Insensitive
- Q = Non-zero dispersion-shifted single-mode

LONG SPAN ADSS

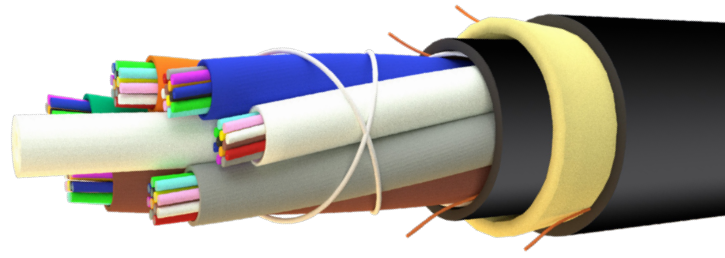

AFL ADSS cables are specifically designed for use on overhead HV transmission and distribution lines with steel lattice towers or wooden, concrete or steel poles.





FEATURES

- Stranded loose tube design ensures that the fibres are always free from mechanical strain under the specified loading conditions
- Double Jacket designs for medium to long span applications and moderate to heavy ice and wind loading conditions
- No metallic or conductive components, allowing the live-line installation (subject to local regulation)
- Torsionally-balanced aramid yarn strength elements provide stable cable design
- UV-resistant polyethylene sheath is compatible with fittings from all major suppliers and is suitable for use to 12kV space potential
- Custom designs for extremely long spans available
- Track-resistant options are also available for use up to 25kV space potential

AD SERIES

DESIGN	FIBRE COUNT	CROSS SECTION	OD	KG/KM	SPAN*	TEMP RANGE °C
AD-72DJA6/3.5	2-72		12	115	75	-40 - 85
AD-72DJA6/09	2-72		13	134	200	-40 - 85
AD-72DJA6/30	2-72		15	178	660	-40 - 85

* Based on 380Pa wind, 12.5mm radial ice, density 915 @ -5C, 1% initial sag

DESIGN	FIBRE COUNT	CROSS SECTION	OD	KG/KM	SPAN*	TEMP RANGE °C
AD-72DJB6/3.5	74-144		15	174	60	-40 - 85
AD-72DJB6/09	74-144		15	174	180	-40 - 85
AD-72DJB6/30	74-144		17	224	570	-40 - 85

* Based on 380Pa wind, 12.5mm radial ice, density 915 @ -5C, 1% initial sag

Single-mode, multi-mode and non-zero dispersion-shifted fibre types are available on request

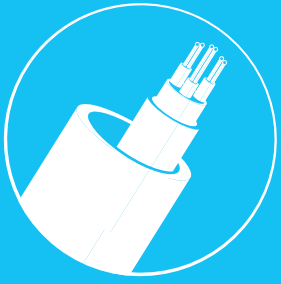

UNDERGROUND CABLE

www.AFLglobal.com

DUCT CABLES

AFL Duct Cables and Flame Retardant Duct Cables are designed with cable strength suitable for pulling into ducts and sub ducts. These designs are also lightweight with a low friction jacket suitable for blowing installations.

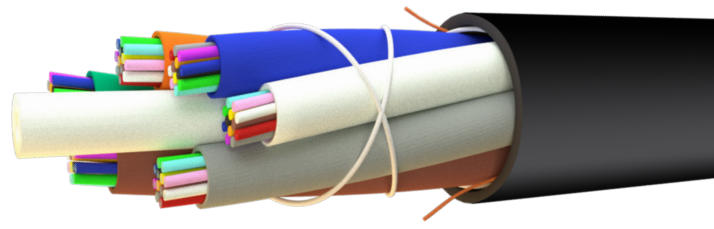





FEATURES

- Fibre counts up to 288
- Fibre management of 6 to 12 tubes
- Dry water-blocking
- Metal-free therefore not subject to EMI or earth-bonding requirements
- Low friction outer sheath for easy handling and installation
- Lightweight and robust construction
- Suitable for blowing or pulling installations
- All Duct cables are tested to the Construction Products Regulation

DUCT CABLE



CPR rated to class F_{CA}

DESIGN	FIBRE COUNT	CROSS SECTION	OD (mm)	kg/km	STRENGTH (kN)	TEMP RANGE (°C)
DU-72CA6/Bk	2-72		10.5	88	2.0	-25 - 65
DU-96CA8/Bk	74-96		12	113	2.0	-25 - 65
DU-144CA12/Bk	98-144		14	139	2.0	-25 - 65
DU-288CA12/Bk	146-288		17	222	2.0	-25 - 65

DUCT CABLES



GLASS REINFORCED DUCT CABLE

CPR rated to class F_{CA}

DESIGN	FIBRE COUNT	CROSS SECTION	OD (mm)	kg/km	STRENGTH (kN)	TEMP RANGE (°C)
DU-72CG6/Bk	2-72		10.5	91	2.7	-25 - 65
DU-96CG8/Bk	74-96		12	123	2.7	-25 - 65
DU-144CG12/Bk	98-144		14	170	2.7	-25 - 65



LSZH DUCT CABLE

CPR rated to class E_{CA}

DESIGN	FIBRE COUNT	CROSS SECTION	OD (mm)	kg/km	STRENGTH (kN)	TEMP RANGE (°C)
DU-72LSA6/Bk	2-72		10.5	118	2.0	-25 - 65
DU-96LSA8/Bk	74-96		12.5	157	2.0	-25 - 65
DU-144LSA12/Bk	98-144		14	176	2.0	-25 - 65

GLASS REINFORCED LSZH DUCT CABLE

CPR rated to class E_{CA}

DESIGN	FIBRE COUNT	CROSS SECTION	OD (mm)	kg/km	STRENGTH (kN)	TEMP RANGE (°C)
DU-72LSG6/Bk	2-72		10.5	117	2.7	-25 - 65
DU-96LSG8/Bk	74-96		12.5	156	2.7	-25 - 65
DU-144LSG12/Bk	98-144		14	188	2.7	-25 - 65

Single-mode, multi-mode and non-zero dispersion-shifted fibre types are available on request

MICROCORE®



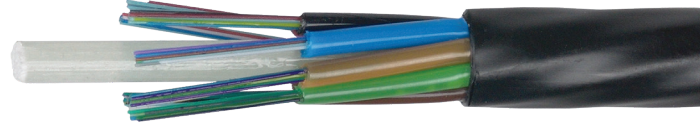

MicroCore® cables are designed for installation by blowing into underground micro-ducts to provide scalable broadband networks with very high implementation rates.



FEATURES & BENEFITS



- Small diameter, lightweight and flexible
- High fibre counts to diameter ratio
- Low friction ribbed jacket to aid jetting process
- Easy-strip jacket for faster splicing and deployment
- Fibres arranged in colour coded buffer tubes
- Metal-free and therefore not subject to EMI or earth-bonding requirements
- MicroCore cables are compatible with micro-ducts supplied by all major manufacturers

250 MICRON RANGE

DESIGN	FIBRE COUNT	CROSS SECTION	OD (mm)	kg/km	STRENGTH (kN)	TEMP RANGE (°C)
MC-72DA6-6.1	2-72		6.1	33	>600	-25 - 65
MC-96DA8-6.6	2-96		6.6	43	>600	-25 - 65
MC-144DA6-7.9	12-144		7.9	55	>800	-25 - 65
MC-144DA12-8.9	12-144		8.9	66	>600	-25 - 65

MICROCORE®

200 MICRON RANGE

DESIGN	FIBRE COUNT	CROSS SECTION	OD (mm)	kg/km	STRENGTH (kN)	TEMP RANGE (°C)
MC200-72DA6	2-72		4.5	18	>600	-25 - 65
MC200-96DA8	2-96		5.2	25	>600	-25 - 65
MC200-144DA12	12-144		6.7	41	>600	-25 - 65

LM 200 MICRON RANGE

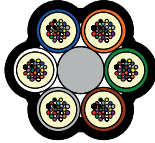
DESIGN	FIBRE COUNT	CROSS SECTION	OD (mm)	kg/km	STRENGTH (kN)	TEMP RANGE (°C)
LM144BAO6101NS	2-144		6.3	34	200	-30 - 70
LM288BAR6101NS	2-288		8.1	56	300	-30 - 70

Single-mode, multi-mode and non-zero dispersion-shifted fibre types are available on request

WRAPPING TUBE CABLE (WTC)

Wrapping Tube Cable (WTC), with SpiderWeb Ribbon® (SWR®), is an ultra-high density outside plant cable designed specifically for fibre-to-the-home (FTTH) or access solutions. It is compliant with the latest international standards for outside plant cables including Telcordia GR-20. With a new ultra-high density ribbon technology called SpiderWeb Ribbon, WTC provides the smallest cable diameter and lowest weight, high-fibre count ribbon cable in the industry. WTC with SWR cables are available in fibre counts from 144 to 3,456.

SWR is a bonded fibre ribbon design allowing for either a highly efficient ribbon splicing or an individual fibre breakout splicing process. This flexibility allows for a single cable design to cover a diverse set of applications from access networks to high-fibre count mass fusion splicing. With the ability to roll and conform, the SWR provides for ultra-high density packaging in the WTC.

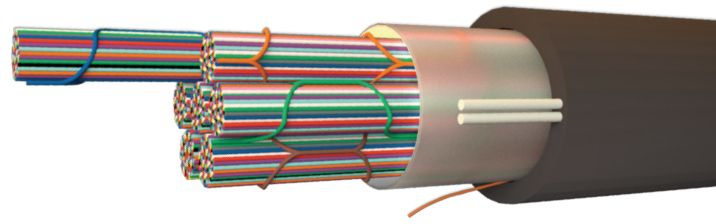

FEATURES

- Access Ready Construction
- Completely gel-free construction with easy-to-access and identify optical fibre circuits.
- SpiderWeb Ribbon (SWR) optical fibre technology
- Easily ribbonised for mass fusion splicing. SWR is compacted and routed like individual fibres. Ideal for organising slack loops in splice enclosures as there is no preferential bending of ribbon.
- Significantly higher fibre density compared to traditional ribbon cables
- Offers ability to expand capacity of existing pathways and allows use of smaller, lower cost duct systems.
- Smaller cable diameters and cable weights
- Means longer reel lengths that allow for lower scrap rates, easier handling of reels at the site and reduced transportation costs.
- Completely dry water-blocking technology
- Reduces time required to prep cable-end and mid-span access resulting in labour savings.
- Compact ribbon bundles
- Reduces enclosure/splice tray size requirements allowing for smaller telecommunications space allocation.
- Armoured and non-armoured packages
- Supports all the standard cable deployment options typically found in the OSP environment including duct, direct buried and aerial.
- Meets IEC Standards
- Provides assurance that the cable will support optical fibre network transport functions now and into the future. Fully qualified to Telcordia GR-20.

CABLE COMPONENTS

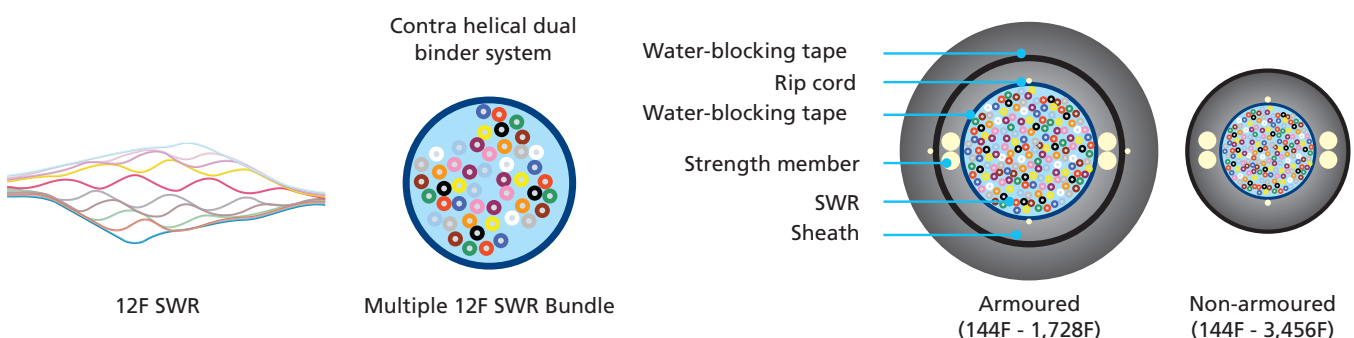

WRAPPING TUBE CABLE (WTC)

MECHANICAL DATA—NON-ARMoured

DESCRIPTION	FIBRE COUNT	BINDER UNIT	NOMINAL DIAMETER	WEIGHT	MAXIMUM TENSILE LOAD		MINIMUM BEND RADIUS	
			INCHES (MM)	LBS/1,000 FT (KG/KM)	SHORT TERM LBS (N)	LONG TERM LBS (N)	SHORT TERM INCHES (MM)	LONG TERM INCHES (MM)
LWSE-144-9-C-144-1-00N1D	144	1 X 144F	0.414 (10.5)	56 (85)	607 (2700)	182 (810)	9 (210)	5 (105)
LWSE-288-9-C-72-4-00N1D	288	4 X 72F	0.473 (12.0)	69 (105)	607 (2700)	182 (810)	8 (180)	5 (120)
LWSE-432-9-C-72-6-00N1D	432	6 X 72F	0.532 (13.5)	88 (135)	607 (2700)	182 (810)	8 (202)	6 (135)
LWSE-576-9-C-72-8-00N1D	576	8 X 72F	0.591 (15.0)	108 (165)	607 (2700)	182 (810)	9 (225)	6 (150)
LWSE-864-9-C-72-12-00N1D	864	12 X 72F	0.689 (17.5)	140 (215)	607 (2700)	182 (810)	11 (262)	7 (175)
LWSE-1152-K-C-144-8-00N1D	1152	8 X 144F	0.721 (18.5)	156 (240)	607 (2700)	182 (810)	11 (278)	8 (185)
LWSE-1728-K-C-144-12-00N1D	1728	12 X 144F	0.871 (23.0)	221 (360)	607 (2700)	182 (810)	14 (345)	9 (230)
LWSE-3456-K-C-144-24-00N1D	3456	24 X 144F	1.182 (30.0)	391 (600)	607 (2700)	182 (810)	18 (450)	12 (300)

MECHANICAL DATA—DOUBLE JACKET SINGLE ARMOUR

DESCRIPTION	FIBRE COUNT	BINDER UNIT	NOMINAL DIAMETER	WEIGHT	MAXIMUM TENSILE LOAD		MINIMUM BEND RADIUS	
			INCHES (MM)	LBS/1,000 FT (KG/KM)	SHORT TERM LBS (N)	LONG TERM LBS (N)	SHORT TERM INCHES (MM)	LONG TERM INCHES (MM)
LWSE-144-9-C-144-1-10S1D	144	1 X 144F	0.630 (16.0)	144 (220)	607 (2700)	182 (810)	10 (240)	7 (160)
LWSE-288-9-C-72-4-10S1D	288	4 X 72F	0.670 (17.5)	166 (255)	607 (2700)	182 (810)	11 (255)	7 (175)
LWSE-432-9-C-72-6-10S1D	432	6 X 72F	0.709 (19.0)	196 (300)	607 (2700)	182 (810)	12 (285)	8 (190)
LWSE-576-9-C-72-8-10S1D	576	8 X 72F	0.808 (20.5)	228 (350)	607 (2700)	182 (810)	13 (307)	9 (205)
LWSE-864-9-C-72-12-10S1D	864	12 X 72F	0.906 (23.0)	277 (425)	607 (2700)	182 (810)	14 (345)	10 (230)
LWSE-1152-K-C-144-8-10S1D	1152	8 X 144F	0.945 (24.0)	300 (460)	607 (2700)	182 (810)	15 (360)	10 (240)
LWSE-1728-K-C-144-12-10S1D	1728	12 X 144F	1.123 (28.5)	401 (615)	607 (2700)	182 (810)	17 (427)	12 (285)

OPTICAL FIBRE

FIBRE COUNT	FIBRE DESIGNATOR	MFD	MAXIMUM ATTENUATION (CABLED) dB/km		
			1310 NM	1383 NM	1550 NM
144, 288, 432, 576, 864	9 (ITU-T G.652D/G.657.A1)	9.2 ± 0.4 µm	≤0.40	≤0.40	≤0.30
1152, 1728, 3456	K (ITU-T G.652D/G.657.A1)	8.6 ± 0.4 µm	≤0.40	≤0.40	≤0.30

STRIPE RING FIBRE IDENTIFICATION

R NO.	STRIPE RING MARKING	R NO.	STRIPE RING MARKING	FIBRE COUNT	BINDER UNIT (BU)	RING MARKINGS
1		7		144F	No Binder Unit	1-12 Ring Marking
2		8		288F	4 Binder Units	1-6 Ring Marking
3		9		432F	6 Binder Units	
4		10		576F	8 Binder Units	
5		11		864F	12 Binder Units	
6		12		1152F	8 Binder Units	1-12 Ring Marking
				1728F	12 Binder Units	1-12 Ring Marking
				3456F	24 Binder Units	1-12 Ring Marking

*For binder units 13-24, the second binder unit is clear

FLAME-RETARDANT WRAPPING TUBE CABLE (WTC)

Flame-retardant (FR) Wrapping Tube Cable (WTC) with SpiderWeb Ribbon (SWR) is a high-density fibre optic ribbon cable intended for inside plant and indoor/outdoor network applications where riser-rated products are required. The FR-WTC-SWR incorporates the leading-edge SpiderWeb Ribbon technology in a robust, flame retardant cable package that can be used within buildings and, because of the core water-blocking feature, can also be routed outside provided the cable is housed within covered pathway spaces including duct-banks and cable trays.

The FR-WTC-SWR product set is available in LSZH, non-armoured (288F up to 1,728F) and FR-PVC double-jacket single-armoured (288-F up to 864F) constructions.

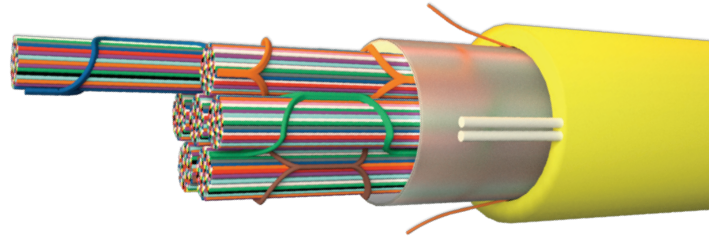

FEATURES

- Collapsible SpiderWeb Ribbon reduces size of cable compared to other encapsulated or pliable ribbon technologies
- Wrapping Tube Cable design optimises the fibre packing density making WTC-SWR cables the smallest ribbon cables without compromising robustness of the cable
- OFNR Riser Rating for routing within designated riser spaces within build structures
- CPR Certified (Non-armoured) is suitable for use in applications requiring European Union (EU) flame, smoke and toxicity classification
- Small Diameter means more optical fibres can be placed into crowded or limited space pathways
- Water-blocked Core allows routing in outside pathways such as duct back or covered cable trays
- Light weight cables are more easily handled in the field compared to traditional cables
- Completely Gel-Free construction reduces fibre access and preparation time for splicing

CABLE COMPONENTS

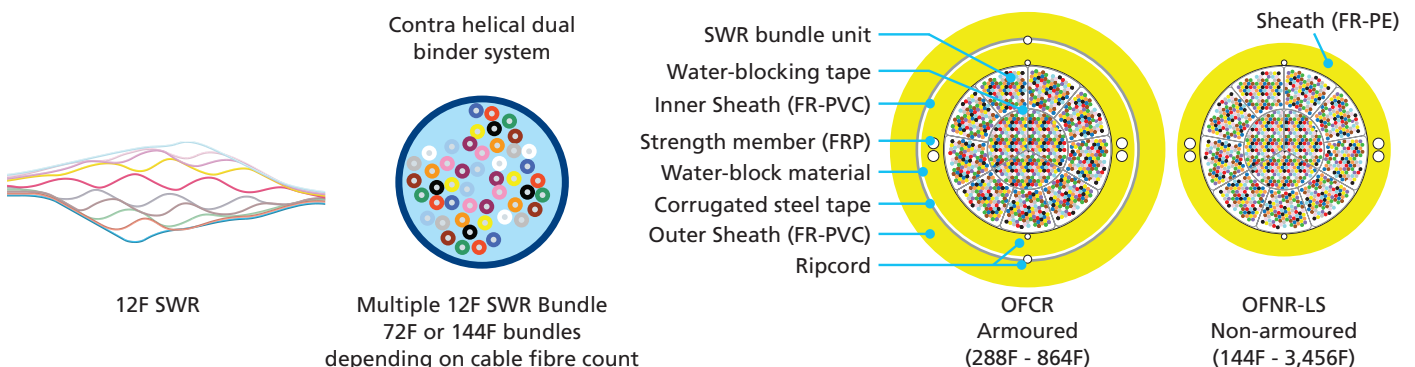

FLAME-RETARDANT WRAPPING TUBE CABLE (WTC)

TEMPERATURE

	Non-Armoured	Armoured
Operating	-20°C to +70°C	-40°C to +70°C
Storage	-40°C to +70°C	-40°C to +70°C
Installation	-10°C to +60°C	-10°C to +60°C

Specifications are subject to change without notice.

STANDARDS COMPLIANCE

Non-Armoured	Armoured
UL 1666, Listed Riser	UL 1666, Listed Riser
ANIS/ICEA S-83-596	UL 1685, Fire Propagation Low smoke
EN 13501-6 (CPR)	ANSI/ICEA-S-83-596

MECHANICAL DATA—NON-ARMOURED

DESCRIPTION	EN 13501-6 CLASSIFICATION	FIBRE COUNT	NOMINAL DIAMETER	WEIGHT	SHORT TERM / INSTALLATION		LONG TERM / STORAGE / STATIC	
			MM	KG/KM	MAX TENSILE LOAD N	MIN BEND RADIUS MM	MAX TENSILE LOAD N	MIN BEND RADIUS MM
FR-OGNM12WTZTWBE-ACEX288C	Cca-s1a, d0, a1	288	13.0	190	1320	254	396	203
FR-OGNM12WTZTWBE-ACEX432C	B2ca-s1, d0, a1	432	15.0	240	1320	304	396	228
FR-OGNM12WTZTWBE-ACEX864C	CCA-S2, D0, A1	864	18.5	340	1320	381	396	304
FR-OGNM12WTZTWBE-SR15EX1728C	CCA-S2, D0, A1	1728	24.0	530	1320	482	396	355

MECHANICAL DATA—DOUBLE JACKET SINGLE ARMOUR

DESCRIPTION	FIBRE COUNT	NOMINAL DIAMETER	WEIGHT	SHORT TERM / INSTALLATION		LONG TERM / STORAGE / STATIC	
		MM	KG/KM	MAX TENSILE LOAD N	MIN BEND RADIUS MM	MAX TENSILE LOAD N	MIN BEND RADIUS MM
FR-OGNM12WTZTWBE-ACEXCTZV-288C	288	19.5	440	2670	381	801	304
FR-OGNM12WTZTWBE-ACEXCTZV-432C	432	21.0	490	2670	432	801	330
FR-OGNM12WTZTWBE-ACEXCTZV-864C	864	24.5	630	2670	482	801	335

OPTICAL FIBRE

OPTICAL FIBRE	FIBRE BUFFER μm	OPTICAL FIBRE STANDARD	MFD	MAXIMUM ATTENUATION (CABLED) dB/km		
				1310 NM	1383 NM	1550 NM
Fujikura ACE (288-864)	250	(ITU-T G.652D/G.657.A1)	$9.2 \pm 0.4 \mu\text{m}$	≤ 0.40	≤ 0.40	≤ 0.30
Fujikura SRI5E (1728)	250	(ITU-T G.652D/G.657.A1)	$8.6 \pm 0.4 \mu\text{m}$	≤ 0.40	≤ 0.40	≤ 0.30

STRIPE RING FIBRE IDENTIFICATION

R NO.	STRIPE RING MARKING	R NO.	STRIPE RING MARKING
1		7	
2		8	
3		9	
4		10	
5		11	
6		12	

FIBRE COUNT	BINDER UNIT (BU)	RING MARKINGS
144F	No Binder Unit	1-12 Ring Marking
288F	4 Binder Units	1-6 Ring Marking
432F	6 Binder Units	
576F	8 Binder Units	
864F	12 Binder Units	
1728F	12 Binder Units	1-12 Ring Marking



WRAP SOLUTIONS

www.AFLglobal.com

SKYWRAP®

Successfully installed worldwide since 1982, SkyWrap is a fibre optic cable helically applied on ground wires or phase conductors. A specially designed spinning machine is used to wrap the cable under controlled conditions. This system offers a complete communication link designed and engineered for high-voltage environments at low cost.

SkyWrap is the ideal solution when access to the overhead line is problematic due to environment or terrain. The installation equipment is lightweight, easy to handle and quick to install. When power outages are hard to coordinate, SkyWrap can be installed on ground wire while the phase conductors remain live or on phase conductors with single circuit outage.

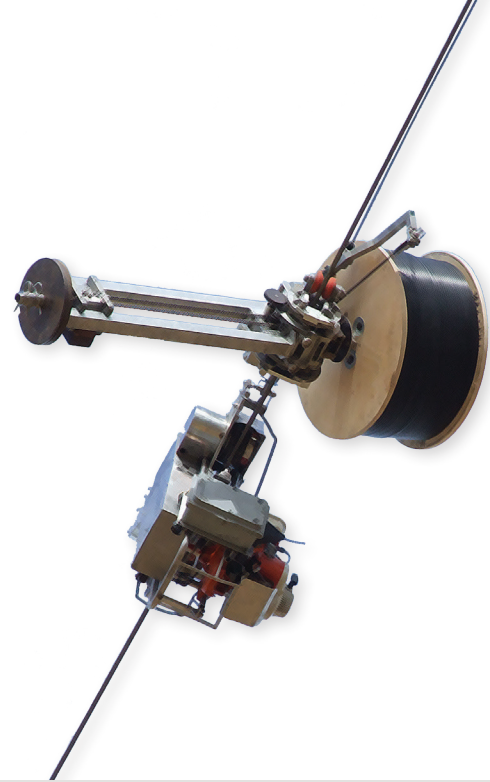

FEATURES

- Suitable for use on distribution lines up to 150kV
- Gel-filled buffer tubes are S-Z stranded for easy mid-span access
- Dual layer jacket design (Birdshot) available for installation in areas prone to shotgun activity.
- Small size and low weight ensures minimum loads are applied to the overhead line

TEMPERATURE

Operating	- 40°C to + 85°C
Storage	- 40°C to + 50°C
Installation	- 20°C to + 50°C

BENEFITS

- Quick, cost effective installation
- Utilise existing power line infrastructure
- Use where access is limited (e.g. mountains and river crossings)
- Use for both ground wires and phase conductors
- Live line installations on ground wire or single circuit outage on phase
- Complete lifetime turn-key solutions
- Over 30 years installation experience

CABLE COMPONENTS

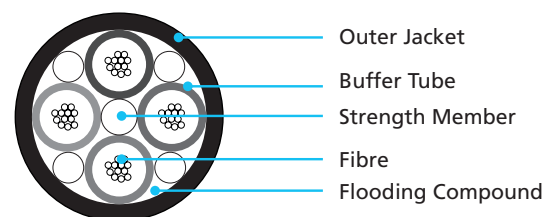

STANDARD DESIGN

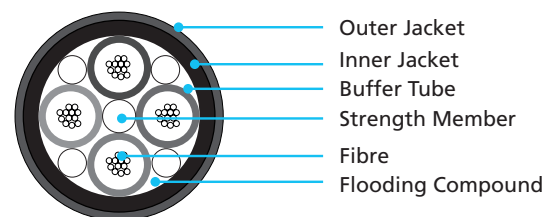

BIRDSHOT DESIGN

PART NUMBER

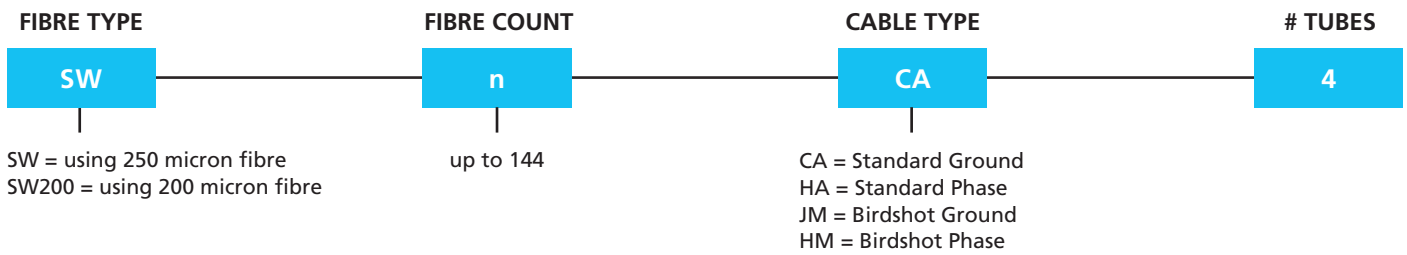

SKYWRAP ORDERING INFORMATION

ITEM NUMBER	FIBRE COUNT	CABLE O.D.	WEIGHT	LENGTH PER REEL	CASSETTE LENGTH
		mm	kg/km	m	m
STANDARD GROUND WIRE					
SW-nCA4	04 - 24	6.4	36	2,440	4,880
SW-nCA4	26 - 48	6.6	39	2,295	4,590
SW-nCA4	50 - 96	8.0	59	1,562	3,124
BIRDSHOT RESISTANT GROUND WIRE					
SW-nJM4	04 - 24	7.3	46	1,826	3,652
SW-nJM4	26 - 48	7.5	50	1,730	3,460
SW-nJM4	50 - 96	8.9	71	1,228	2,456
SW200-nJM4	100-144	8.7	55	1,285	2,570
STANDARD PHASE CONDUCTOR					
SW-nHA4	04 - 24	7.3	55	1,914	3,828
SW-nHA4	26 - 48	7.5	59	1,813	3,626
SW-nHA4	50 - 96	8.9	82	1,288	2,576
BIRDSHOT RESISTANT PHASE CONDUCTOR					
SW-nHM4	04 - 24	8.0	61	1,594	3,188
SW-nHM4	26 - 48	8.2	65	1,517	3,034
SW-nHM4	50 - 96	9.6	89	1,107	2,214
SW200-nHM4	100-144	9.4	81	1,154	2,308

Note: Diameter and weight subject to change without notice
Single-mode, multi-mode and non-zero dispersion-shifted fibre types are available on request

INSTALLATION EQUIPMENT INFORMATION

PARAMETER	VALUE
Typical Weight (includes cable and balance weight)	250kg
Min-Max Radius of rotation	0.87-1.45m
Wrapping Speed	5km per hour

INSTALLATION HARDWARE

A full range of hardware and accessories are available as part of the SkyWrap solution. Many different options are available to suit individual structure types and environmental conditions. Please contact AFL for more information.

HIGH VOLTAGE SKYWRAP®

High Voltage SkyWrap is a specialised solution that permits the installation of SkyWrap onto phase conductors at system voltages of up to 300kV. The solution is applicable for power lines without ground wires with conductors running at system voltages between 150-300kV, opening up new transmission lines for power utilities to add fibre optic cable to their power network.

The system is developed, tested and approved to the applicable standards for working in this challenging environment, while maintaining all the key features and benefits of the SkyWrap system in terms of ease and speed of installation.



FEATURES

- System developed exclusively for system voltages of 150kV to 300kV with no ground wire.
- Solution qualified to IEEE 1591.3 standard including Tracking & Erosion and Leakage Current.
- Solution tested against RIV and PD to CISPR 18-2.
- Pre-made Phase-To-Ground Insulator system ensures quick, simple and secure installation of critical components.
- Key features of SkyWrap cable retained, with dual layer anti-tracking sheath providing protection against shotgun damage, UV light, pollution, lightning and fault current conditions and electric field effects.
- Small size and low weight ensures minimum loads are applied to the overhead line

TEMPERATURE

Operating	- 40°C to + 85°C
Storage	- 20°C to + 50°C
Installation	- 10°C to + 50°C

CABLE COMPONENTS

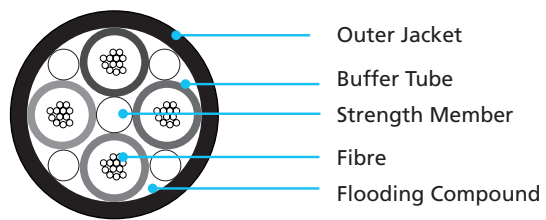

PART NUMBER



SKYWRAP ORDERING INFORMATION

ITEM NUMBER	FIBRE COUNT	CABLE O.D.	WEIGHT	LENGTH PER REEL	CASSETTE LENGTH
		mm	kg/km	m	m
STANDARD PHASE CONDUCTOR					
SW-nHA4	04 - 24	7.3	55	1,914	3,828
SW-nHA4	26 - 48	7.5	59	1,813	3,626
SW-nHA4	50 - 96	8.9	82	1,288	2,576
BIRDSHOT RESISTANT PHASE CONDUCTOR					
SW-nHM4	04 - 24	8.0	61	1,594	3,188
SW-nHM4	26 - 48	8.2	65	1,517	3,034
SW-nHM4	50 - 96	9.6	89	1,107	2,214
SW200-nHM4	100-144	9.4	81	1,154	2,308

Note: Diameter and weight subject to change without notice
Single-mode, multi-mode and non-zero dispersion-shifted fibre types are available on request

ACCESSWRAP™

AccessWrap provides a quick, cost effective and sustainable solution for fibre deployment on the distribution section of power lines.

Based on proven SkyWrap® technology, cable is wrapped around the existing overhead power line infrastructure with minimal disruption to service and no modification requirements to structures. The cable can be wrapped on phase conductors up to 50kV and is designed to withstand the aggressive environments of aerial applications in any climate.

AFL provides a complete solution to include line survey, cable, hardware and machine supply, project and installation management as well as warranty and maintenance services.



FEATURES

- Quick, cost effective installation
- Fibre counts up to 48, multiple fibre types available
- Zero fibre strain under all service conditions
- Minimal environmental impact
- Installation equipment weight and size is specially designed for installation on short span, compact conductors of up to 50kV
- Specially designed accessories supplied:-
- Lightweight in-line splice case
- Phase-To-Ground insulators
- Compact pole mounted splice case

TEMPERATURE

Operating	- 40°C to + 85°C
Storage	- 20°C to + 50°C
Installation	- 10°C to + 50°C

BENEFITS

- Utilise existing power line infrastructure to minimise capital investment
- Minimise or eliminate deferred cost related to electrical infrastructure investment
- Alleviate problems of land access and areas of difficult terrain
- Extend fibre networks to remote LTE equipment in the roll out of mobile 5G
- Connectivity where terrain and line of sight issues make wireless less reliable
- Extend customer reach for FTTx applications particularly in rural and remote areas
- Integration as part of Smart Metering technology

CABLE COMPONENTS

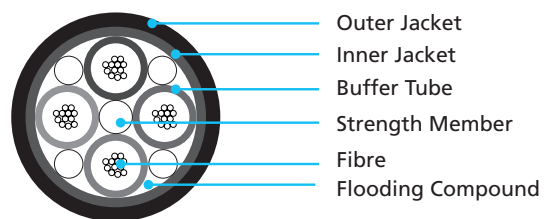

ACCESSWRAP™

PART NUMBER



ACCESSWRAP ORDERING INFORMATION

ITEM NUMBER	FIBRE COUNT	CABLE O.D.	WEIGHT	LENGTH PER REEL	CASSETTE LENGTH
		mm	kg/km	m	m
SW-nHC4	06 – 12	5.6	30	871	1,742
SW-nHC4	13 – 24	6.2	36	700	1,400
SW200-nHC4	25 – 48	6.2	36	700	1,400

Note: Diameter and weight subject to change without notice
Single-mode, multi-mode and non-zero dispersion-shifted fibre types are available on request

INSTALLATION EQUIPMENT INFORMATION

PARAMETER	VALUE
Typical Weight (includes cable and balance weight)	45kg
Min-Max Radius of rotation	0.5m
Wrapping Speed	Up to 5km per hour

INSTALLATION HARDWARE

A full range of hardware and accessories are available as part of the AccessWrap solution. Many different options are available to suit individual structure types and environmental conditions. Please contact AFL for more information.

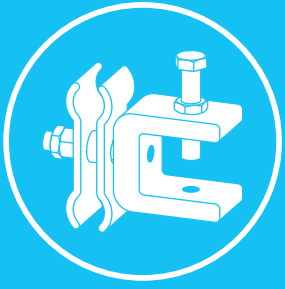

ACCESSORIES/ HARDWARE

www.AFLglobal.com

OPGW FITTINGS

AFL is a full solution provider for OPGW systems, from cable and hardware supply to route planning and installation. With over 250,000km of OPGW supplied worldwide AFL can offer the experience and expertise to help identify the best tailored solution. OPGW hardware and accessories are specified for the installation and efficiency of individual power line infrastructure requirements. Example fittings can be seen below.

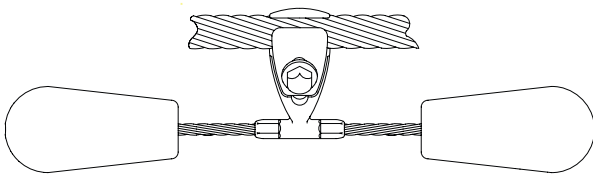

Stockbridge Vibration Dampers

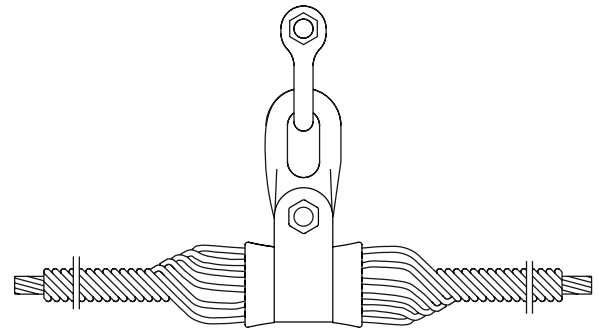

Suspension Sets

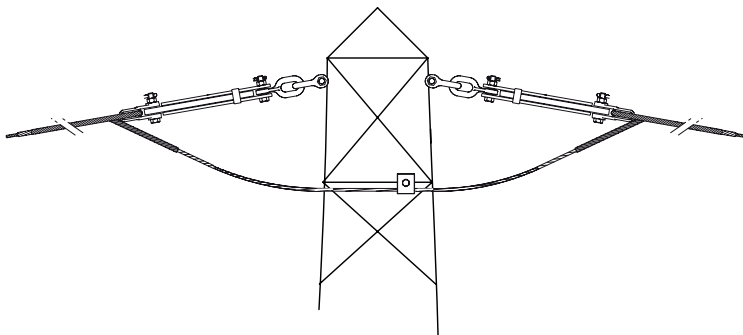

Tension Sets



Dome Closures

REQUIRED INFORMATION FOR ORDERING

Hardware and accessories are specified according to the tower and conductor configurations, span lengths, cable type and environmental conditions. AFL will ask for these details in order to be able to specify the recommended arrangements.

OPGW STAINLESS STEEL DOME CLOSURE

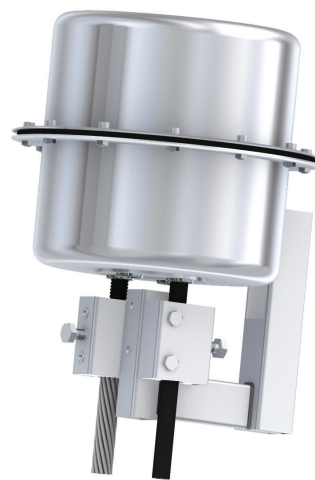

CONFIGURATION

CABLE ENTRIES		4
OPGW/ OPTICAL MODULE, DIAMETER	mm	9-20 / 2.5-3.5 (stranded) 6.5 (central)
STEEL TUBE PER OPGW		3
APPROACH CABLE/ ADSS, DIAMETER	mm	9-15.5 / 9-15.5
NUMBER OR SPLICES		192 (extendable)

CHARACTERISTICS

TOTAL HEIGHT	mm	353
WIDTH, MAX.	mm	290.5
WEIGHT	kg	7.0

TOWER FIXING

UNIVERSAL CLAMP	mm	9-20 (cable diameter)
LATTICE TOWER CLAMP	mm	max. 23 (clamping range)
CIRCULAR POLE CLAMP	mm	max. 600

KEY COMPONENTS

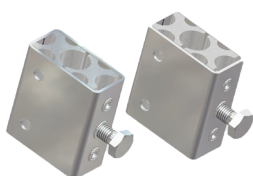

UNIVERSAL CLAMP
20113064

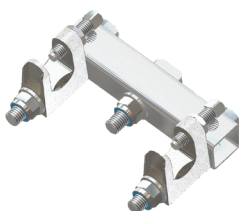

LATTICE TOWER CLAMP
10115814

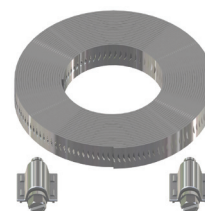

CIRCULAR POLE CLAMP
10115813

IDENTIFICATION

OJB	-	1	-	OOEB	-	C	-	048
-----	---	---	---	------	---	---	---	-----

O - Entry, OPGW
E - Entry, approach
cable / ADSS
B - Unused entry

C - Crimp splice
protection
H - Heat shrinkable
splice protection

Maximum number of
splices (steps: 48)

OPGW ALUMINIUM DOME CLOSURE



CONFIGURATION

CABLE ENTRIES		4
OPGW/ OPTICAL MODULE, DIAMETER	mm	8-31 / 2.5-3.5
STEEL TUBE PER OPGW		3
APPROACH CABLE/ ADSS, DIAMETER	mm	11-16 / 16-20
NUMBER OR SPLICES		144 (crimp) or 72 (heat shrinkable)

CHARACTERISTICS

TOTAL HEIGHT	mm	500
WIDTH, MAX.	mm	243
WEIGHT	kg	7.5

TOWER FIXING

UNIVERSAL CLAMP	mm	8-31 (cable diameter)
CLAMPING SET, LATTICE TOWER	mm	max. 15 (clamping range)
CIRCULAR TOWER DIAMETER	mm	max. 600

KEY COMPONENTS

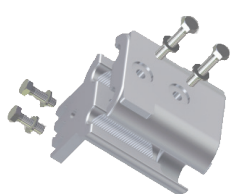

CABLE CLAMP FOR 2 CABLES

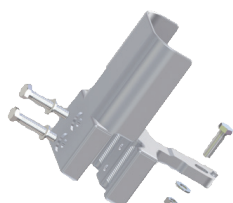

CABLE CLAMP AND EXTENSION FOR MORE THAN 2 CABLES

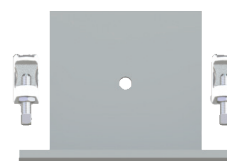

LATTICE TOWER CLAMP
10110795

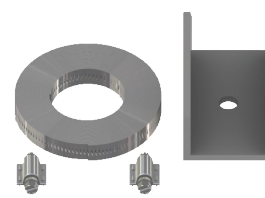

CIRCULAR POLE CLAMP
10110794

IDENTIFICATION

LH	2/72	-	OOEB / OOEC	-	C	-	036
----	------	---	-------------	---	---	---	-----

O - Entry, OPGW
E - Entry, approach cable / ADSS
B - Unused entry

C - Crimp splice protection
H - Heat shrinkable splice protection

Maximum number of splices

OPGW ACCESSORIES

AFL provides a full range of hardware and accessories for OPGW and OPPC cable installations. Please contact AFL for more details

MANUAL DISPENSER VBM 400 X (MR)



Hand held dispenser gun for System 400 cartridges, mixing ratio 4:1

Order number: 10117249

STEEL TUBE CUTTER STC-III

Steel tube cutting tool for cutting steel tubes up to 5.7mm diameter.

Order number: 10116136

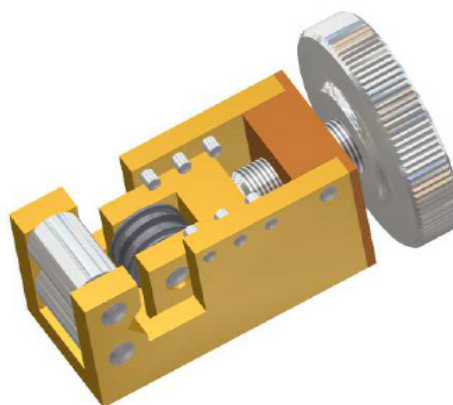







Specially shaped blade indents the steel tube to protect the optical fibres.



OPTICAL PHASE CONDUCTOR INSULATORS

Optical Phase Conductor (OPPC) insulators are designed to splice the optical fibres of the energised OPPC with fibres of a metal free fibre optic cable which can be connected to a cabinet in the substation. AFL provide a range of hollow composite insulators to suit a range of voltage levels and applications which are specified to IEC 61462 & IEC 62217 standards.

Type	Spliceless	S - Standing		H - Hanging		P - Hanging, fixed on plate	
							
Tension U_m	24-36	36-145	245	36-145	245	36-145	245
OPPC entries	1	1-2					
OPPC / Steel tube diameter (mm)	10-28 / 2.5-3.5	10, 28, 39 / 2.5 - 3.5					
Approach cable entries	1	1-4					
Approach cable diameter (mm)	10-28	11.5 - 18					
Number of splices	-	144 crimp or 72 heat shrinkable					

CHARACTERISTICS

TENSION, U_M	KV	24 Spliceless		36 Spliceless		36		52		72.5		123		145		245	
Pollution class (IEC 60815)		II	IV	II	IV	II	IV	II	IV	II	IV	II	IV	II	IV	II	IV
ID number		04K3113 /1	05K4193	05K4197	05K4198	00K8153	05K4165	02K0357	05K4166	01K9683	05K4148	02K0358	05K4210	01K9094	05K4167	05K4225 /A	05K4168 /A
Number sheds (diameter)	mm	3 (138)	5 (138)	4 (138)	7 (138)	4 (160)	7 (160)	5 (160)	10 (160)	8 (160)	12 (160)	13 (160)	24 (160)	16 (160)	28 (160)	25 (178)	47 (178)
Creepage	mm	575	855	740	1190	740	1190	1040	1700	1540	2325	2460	3930	3000	4560	4900	7640
Arcing distance, minimum	mm	219	259	259	349	260	350	450	500	580	885	960	1050	1080	1200	1850	1950
Dry lightning voltage *	kV	145	145	170	170	170 (173.92)	170 (230.94)	250 (293.92)	250 (325.26)	325 (357.43)	325 (544.97)	550 (590.98)	550 (646.13)	650 (664.50)	650 (737.91)	1050 (1133.64)	1050 (1194.24)
Wet power frequency volt.*	kV	50	50	70	70	70 (80.22)	70 (120.42)	95 (161.88)	95 (181.33)	140 (186.48)	140 (307.05)	230 (334.92)	230 (367.43)	275 (378.04)	275 (419.35)	460 (611.84)	460 (636.76)
Total height, type S & P	mm	-	-	-	-	941.5	1031.5	1181.5	1131.5	1261.5	1566.5	1641.5	1731.5	1761.5	1881.5	2730	2830
Total height, type H	mm	-	-	-	-	1039	1129	1229	1279	1359	1664	1739	1829	1859	1979	2827.5	2927.5
Weight (approx), type S / H / P	kg	-	-	-	-	30 / 26 / 29	31 / 27 / 30	31 / 27 / 30	32 / 28 / 31	32 / 28 / 31	34 / 30 / 33	34 / 30 / 33	37 / 33 / 36	35 / 31 / 34	38 / 34 / 37	56 / 52 / 55	65 / 58 / 61
Total height, type spliceless	mm	629	669	669	759	-	-	-	-	-	-	-	-	-	-	-	-
Weight (approx), type spliceless	kg	3.8	4.2	4	4.6	-	-	-	-	-	-	-	-	-	-	-	-

* Values : IEC 60071-1 (statistical)

OPTICAL PHASE CONDUCTOR INSULATORS

DIMENSIONS OF FIXINGS (MM)

BASE PLATE

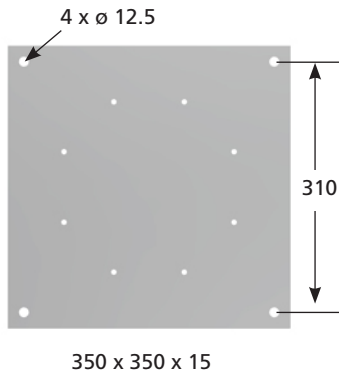

MOUNTING EYE

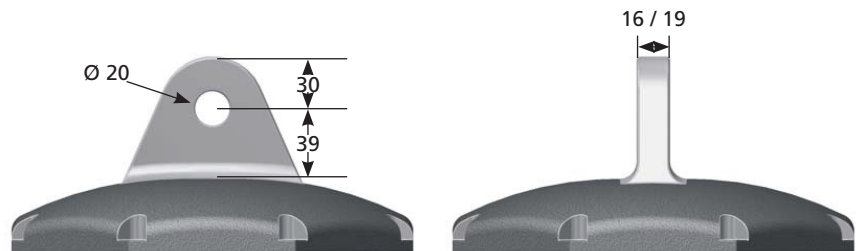

SPLICELESS TOP / BOTTOM

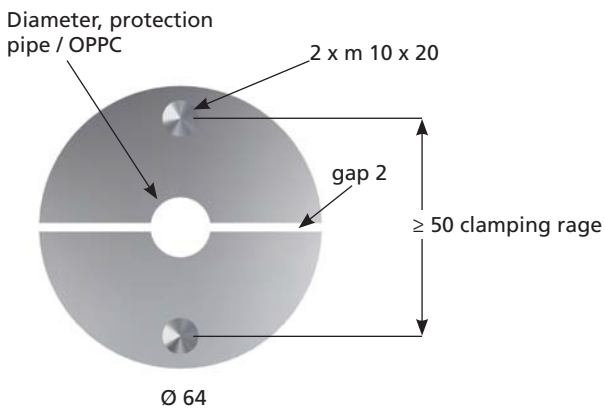

OPPC INSULATOR IDENTIFICATION

SEP	S	01K9683	II	72.5	19
Type	ID Number	Pollution class (IEC 60815)	Tension U_m	Mounting eye width	
S = Standing				16 = 16mm	
H = Hanging				19 = 19mm	
P = Hanging, fixed on plate				Blank = Spliceless	
Blank = Spliceless					

Example: SEP-S-01K9683-I-72.5-19

OPPC JOINT BOXES

Optical Phase Conductor (OPPC) Joint Boxes are designed to connect two OPPC fibre optic cables. These boxes must be installed without having contact to tower structure. They can be connected to a hanging insulator at suspension towers or in the loop between two insulators at tension towers.

JOINT BOX DESIGNS

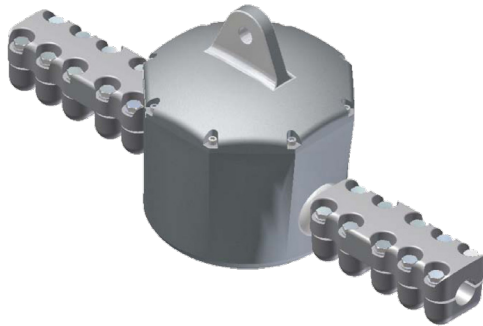

CJB-1



CJB-3

OPPC entries	2
OPPC / steel tube diameter (mm)	10-39 / 2.5-3.5
Number of splices (FiberArt™)	144 crimp or 72 heat shrinkable

OPPC entries	2
OPPC / steel tube diameter (mm)	10-21 / 2.5-3.5
Steel tubes per OPPC	3
Number of splices (FiberArt™)	144 crimp or 72 heat shrinkable

CHARACTERISTICS

		TERMINATION SPLICE	SELF SUPPORTING INLINE SPLICE
Tension U_M	kV	36-245	24-123
Short time current, I^2t	kA ² s	3600	3600
Total height (incl. mounting eye)	mm	314.5	240 (295)
Width, S (OPPC, Ø: 10 - 28 mm)	mm	612	
Width, L (OPPC, Ø: 28 - 39 mm)	mm	674	
Total width	mm		405
Width, main body	mm		240
Depth	mm		108
Weight (approx.)	kg	15	10

DIMENSIONS OF FIXINGS (MM)

MOUNTING EYE - CJB-1

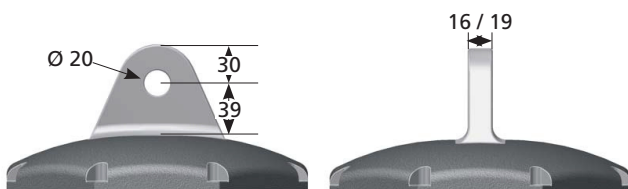

MOUNTING EYE - CJB-3

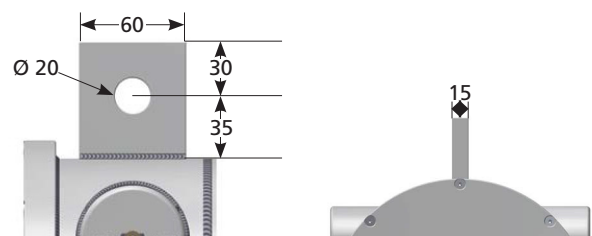

OPPC JOINT BOX IDENTIFICATION

CJB	3	N	-E
Type	1 = Universal	S = 2 x OPPC, Ø 10 - 28 mm L = 2 x OPPC, Ø 28 - 39 mm, M = mixed	E = including mounting eye
	3 = Limited voltages	N = 2 x OPPC, Ø: 10 - 21 mm M = 2 x OPPC, Ø: 10 - 21 mm, mixed	EE = Fixing eye, width

Example: CJB-1-5-19 or CJB-3-N-E

ADSS FITTINGS

ADSS fittings are used to fix ADSS cables to poles or lattice towers. The correct ADSS cable fitting is decided by the cable outer diameter and the span length that needs to be covered. For short, medium and long spans, AFL ADSS fittings offer customers reliable performance for efficient network operation.

AFL supplies a wide range of attachment hardware which simplifies the network design phase of a project while ensuring compatibility between the cable and related components. For more information, please contact AFL to further discuss your requirements.

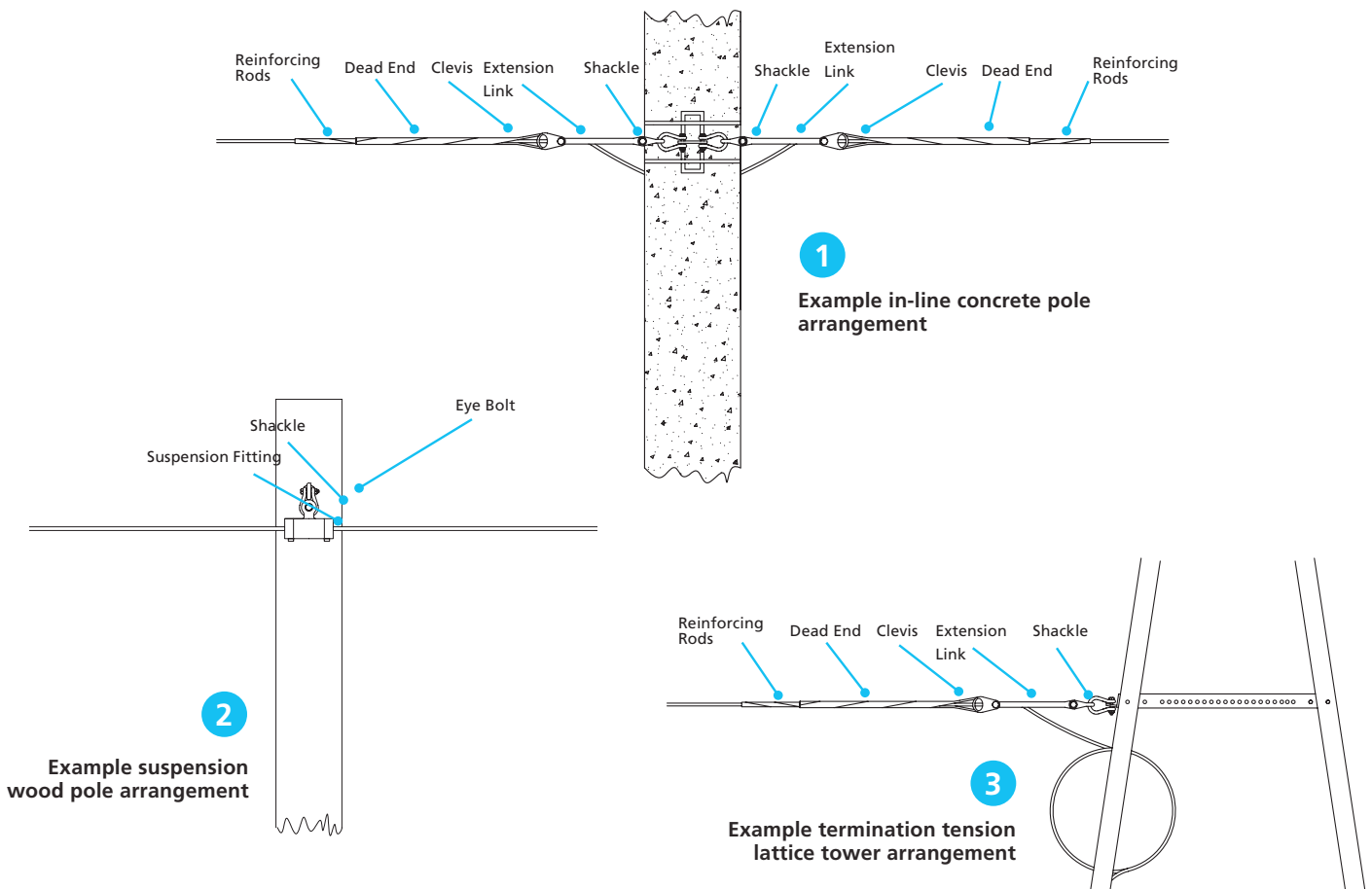

ORDERING INFORMATION

ARRANGEMENT TYPE	STRUCTURE TYPE			MINIMUM ADSS CABLE OD (MM)	MAXIMUM ADSS CABLE OD (MM)	MAXIMUM SPAN LENGTH (M)
In-line Tension	Wood Pole	TCD	3000	NNN	MMM	SSS
In-line Tension	Concrete Pole	TCD	3001	NNN	MMM	SSS
In-line Tension	Lattice Tower	TCD	3002	NNN	MMM	SSS
Termination Tension	Wood Pole	TCD	3003	NNN	MMM	SSS
Termination Tension	Concrete Pole	TCD	3004	NNN	MMM	SSS
Termination Tension	Lattice Tower	TCD	3005	NNN	MMM	SSS
Suspension	Wood Pole	TCD	3006	NNN	MMM	SSS
Suspension	Concrete Pole	TCD	3007	NNN	MMM	SSS
Suspension	Lattice Tower	TCD	3008	NNN	MMM	SSS

Example: TCD-3001 14.5-15.5 300

SKYWRAP® GROUND WIRE HARDWARE

A full range of hardware is available for fixing the SkyWrap cable to ground wire tower arrangements. The cable can be passed around tower tops using a specially designed bypass accessory known as a 'balehanger'. SkyWrap cable is passed down the tower to joint enclosures or termination joints in protective conduits. All cable clamps are supplied for fixing the SkyWrap cable as required.

FEATURES

- Fittings meet IEEE standard 1591.3 and cable complies with IEEE 1594
- All tower fittings are available for a range of tower or pole designs
- Tower mounted enclosure boxes are 830 x 380 x 260 mm and are made to BS EN 50411-3 standard
- All accessories are robust, weather-proof design
- Suitable for up to 144 fibres or 288 fibres with double SkyWrap applied
- Joint enclosure can be locked for added security

TYPICAL TOWER ARRANGEMENTS

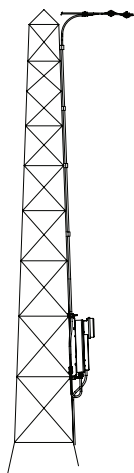

1 TERMINATION JOINT

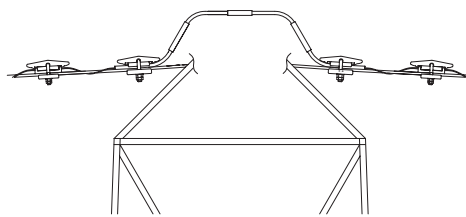

2 IN-LINE BYPASS

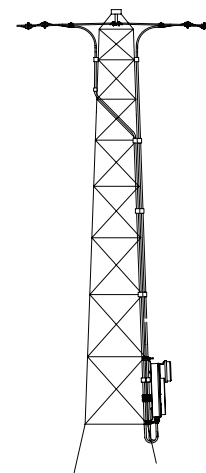

3 IN-LINE JOINT

ORDERING INFORMATION

ARRANGEMENT	TOWER HEIGHT METRES	TOWER HEIGHT METRES			STRUCTURE TYPE			CONDUCTOR SIZE mm			DOUBLE WRAP	FIBRE COUNT
		< 25	< 35	< 60	Lattice Tower	Steel/Concrete Pole	Wood Pole	9-22	20-31	30-43		
1 Termination joint	TCD	L	M	H	902	906	962	A	B	C	D	nnF
2 In-Line bypass	TCD	-	-	-	909	909	909	A	B	C	D	-
3 In-Line Joint	TCD	L	M	H	901	905	961	A	B	C	D	nnF

Example: TCD-L906BD48F or TCD-909A

SKYWRAP® PHASE WIRE HARDWARE

A full range of hardware is available for fixing the SkyWrap cable to phase wire tower arrangements. The cable is passed around and kept away from conductor fittings using a specially designed bypass accessory known as 'balehanger'. SkyWrap cable is passed down the tower to joint enclosures or termination joints via a specially design system called Phase-to-Ground. This system provides electrical isolation and mechanical support to transition the SkyWrap cable from phase conductor to a tower mounted enclosure. Conductor mounted enclosures or 'donuts' are also available for SkyWrap cable, this enclosure is held at the same electric potential as the conductor keeping the joint protected by the Faraday Effect. Hardware fittings are available for tension and suspension tower designs using lattice towers, wood, steel or concrete poles.

FEATURES

- Robust weather-proof track resistant designs to suit environmental and polluted conditions
- Available for up to 288 fibres
- Tower mounted enclosure boxes are 830 x 380 x 260 mm and are made to BS EN 50411-3 standard
- Meets IEEE standard 1591.3
- Phase-to-Ground complies with IEC 60 and IEC 1109 standards
- Donut complies with IEC 60060-1, IEC 61109, IEC 60437, BS 5049 part 2-994, CISPR18-2 standards
- Joint enclosures made to BS EN 50411-3 standard
- Suitable for up to 300 kV system voltage

KEY ACCESSWRAP COMPONENTS FOR SYSTEM VOLTAGES UP TO 50KV

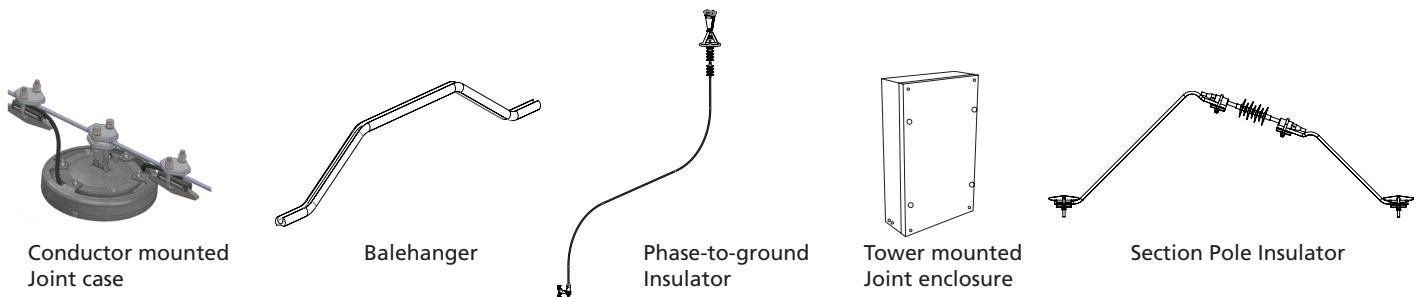

KEY COMPONENTS FOR SYSTEM VOLTAGES UP TO 150KV

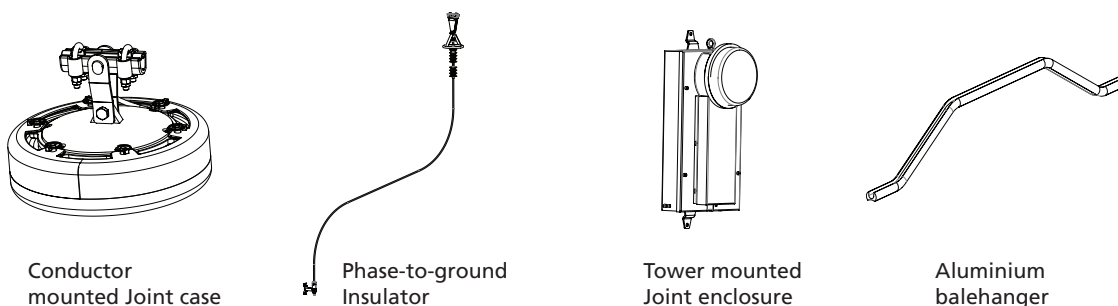

KEY COMPONENTS FOR SYSTEM VOLTAGES UP TO 300KV

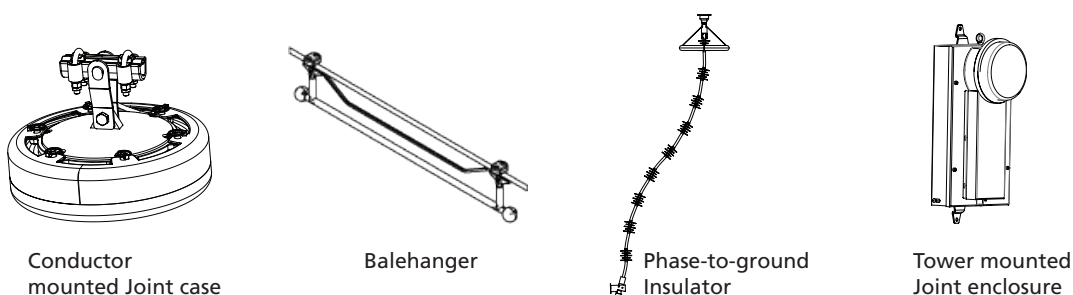

SKYWRAP PHASE WIRE HARDWARE

TYPICAL TOWER ARRANGEMENTS

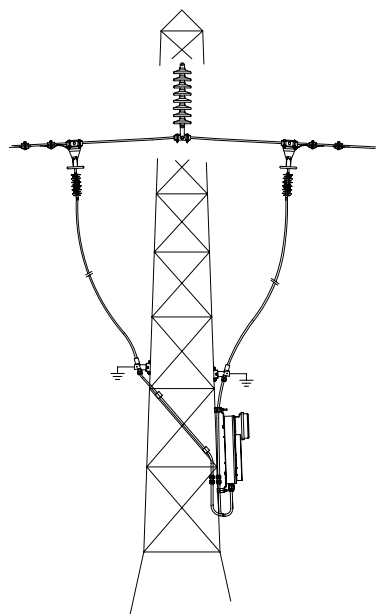

1 IN-LINE JOINT



2 TENSION BYPASS

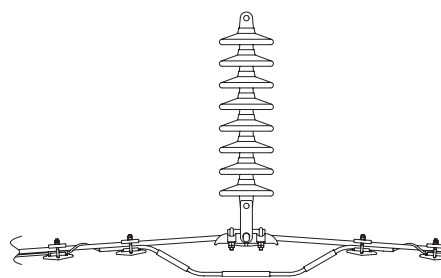

3 SUSPENSION BYPASS

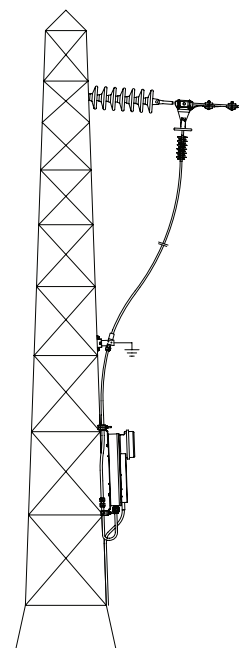

4 TERMINATION JOINT

ORDERING INFORMATION

ARRANGEMENT	System kV	TOWER HEIGHT metres			STRUCTURE TYPE					CONDUCTOR SIZE mm				Double Wrap	FIBRE COUNT	
		< 25	< 35	< 60	Lattice Tower	Steel/Concrete Pole	Wood Pole	Tension	Suspension	9-22	20-31	30-43	42-60			
1 In-line Joint	50	TCD	L	M	H	-	1016	1016	-	-	A	B	C	-	D	nnF
	150	TCD	L	M	H	912	916	920	-	-	A	B	C	-	D	nnF
	300	TCD	-	-	-	301	-	-	-	-	B	C	D	D	nnF	
2 Tension bypass	50	TCD	-	-	-	-	1010	1010	-	-	A	B	C	-	D	-
	150	TCD	-	-	-	927	927	927	-	-	A	B	C	-	D	-
	300	TCD	-	-	-	308	-	-	-	-	B	C	D	D	nnF	
3 Suspension Bypass	50	TCD	-	-	-	-	1009	1009	-	-	A	B	C	-	D	-
	150	TCD	-	-	-	926	926	926	-	-	A	B	C	-	D	-
	300	TCD	-	-	-	303	-	-	-	-	B	C	D	D	nnF	
4 Termination joint	50	TCD	L	M	H	-	1017	1017	-	-	A	B	C	-	D	nnF
	150	TCD	L	M	H	913	917	921	-	-	A	B	C	-	D	nnF
	300	TCD	-	-	-	302	-	-	-	-	B	C	D	D	nnF	
Conductor mounted joint	50	TCD	-	-	-	-	1025	1025	-	-	A	B	C	-	D	-
	150	TCD	L	M	H	-	-	-	924	925	A	B	C	-	D	nnF
	300	TCD	-	-	-	306	-	-	-	-	B	C	D	D	nnF	

Example: TCD-L916BD48F or TCD-927A



CONNECTIVITY

www.AFLglobal.com

ULTRA HIGH DENSITY OPTICAL DISTRIBUTION FRAME

A scalable Optical Distribution Frame (ODF) built around the Ultra High Density module, offering maximised port capacity in a minimised footprint. Its unique design provides a governance model for patch cord routing which maximises port utilisation and aids MAC's. This ODF enables rapid expansion and scalable growth in an all front access format, supporting both 'mid' and 'end' of suite line deployments. OSP cable entry available from above or below, with tie-cables exiting to overhead cable containment from the top right of the frame.



FEATURES

- All Front Access
- Up to 1440 splice capacity
- Up to 2880 port capacity
- On frame patch management
- Lockable & removable doors & side panel

BENEFITS

- Only four lengths of patch cord required
- Modular design enables cost deferment
- Rapid capacity upgrades
- Maximised port utilisation

APPLICATIONS

Suitable for Telecoms applications such as cable head, cross connect, interconnect and where pre-terminated tie cables are required to offer Ultra High Density connectivity between Network Elements.

MODULAR ODF SOLUTIONS



ULTRA HIGH DENSITY 1U CHASSIS

1U Ultra High Density (UHD) Chassis is the part of the system for high density fibre optics infrastructure management in Data Centres, Telecommunication and Enterprise environment. 1U chassis can house up to 5 x UHD Modules- design allows to scale up to 120x LC ports and 960 fibres using MPO/ MTP Interface.

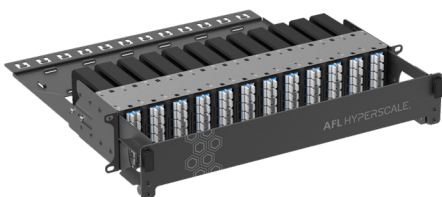

ULTRA HIGH DENSITY 2U CHASSIS

2U Ultra High Density (UHD) Chassis is the part of the system for high density fibre optics infrastructure management in Data Centres, Telecommunication and Enterprise network environment. 2U chassis can house up to 12 x UHD Modules- design allows to scale up to 288x LC ports and 2304 fibres using MPO Interface.

AM SERIES PANELS

A range of sliding metal 19" panels used to host variable quantities of LGX style adapter plates. With the ability to use a full array of adapter styles, these panels offer a flexible solution to the end user, enabling them to incorporate a multi functional chassis with easy access during installation or rework and no disturbance of the existing cable or fibres. In addition to the array of adaptor options available the AM series also offers multiple cable entry solutions, the ability to accept OSP, ISP & pre-terminated cables & optional splice cassettes also allow standard splicing.



FEATURES

- LGX style modularity
- OSP, ISP & Pre-term compatible
- Multiple cable entry options
- Wide range of adapter options
- Broad range of capacities

BENEFITS

- Sliding tray offers easy access to splice area
- Quick installation
- Includes all fixings
- Supports both Plug & Play and spliced networks

APPLICATIONS

Ideally suited to medium and high density CO cross/inter connect applications.



1,2,3 & 4U versions available

Available with/out: Pigtails, adapters, splice trays
Accepts SC, LC, FC, ST, E2000 & blank adapter plates



FIBRE ENTRY SOLUTIONS

Requirements for Fibre Entry Solutions will vary determined by the scale of the Central Office. We are able to offer a comprehensive range of products and solutions that can cater for fibre counts from a single fibre up to 6912.

Different solutions are available depending on the type of cable being deployed, from Tight Buffered, Loose Tube and Blown, right up to the latest Ultra High Density Wrapping Tube Cables

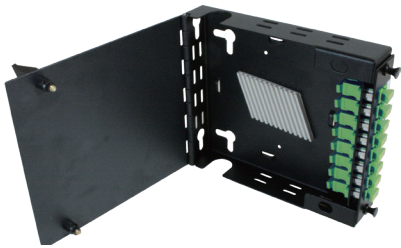

AMW1 WALL BOX
LOW DENSITY

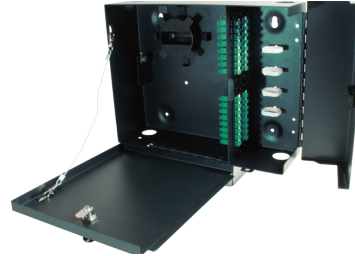

AMW4 WALL BOX
HIGH DENSITY

The AMW range of indoor wall mounted splice enclosures offers a compact solution to the end user. These enclosure have been designed to accept LGX style assemblies. With the ability to use a full array of adapter types this enclosure offers a flexible solution to the end user, enabling them to incorporate a multi functional enclosure that allows easy access during installation or rework with no disturbance of the existing cable or fibres. In the addition to the array of adapters the enclosure also offers multiple cable entry solutions, fibre cable can be spliced or pre terminated solutions, making this enclosure one of the most flexible on the market.

CONSUMABLES

Our Premium Range of Low-Loss Patch Cords is suitable for Telecom, Data Centre and Mission Critical Applications provide flexible inter-connection to Active Equipment, Passive Optical Devices and Cross-Connects.

All Patch Cords are terminated with Ultra Physical Contact (UPC) or Angled Physical Contact (APC) Zirconia Ferrule Connectors manufactured with precision factory mounting and polishing techniques, assuring high transmission quality.



Premium Patch Cords

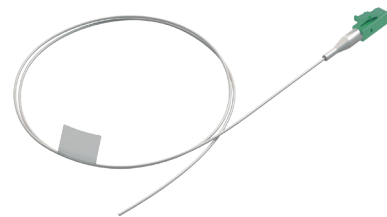

Premium Pigtails

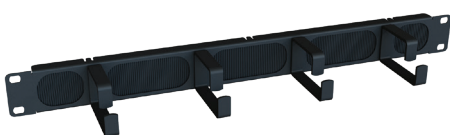

Cable Management

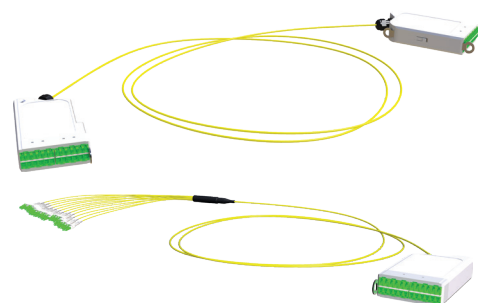

Pre-term Assemblies

FAFL **PROJECT SERVICES**

Along with a broad range of products, AFL Project Services Department provides project design, installation maintenance and management services to support the sale and deployment of AFL's products.

Please contact your AFL sales representative for more information about any of our products or services

www.AFLglobal.com
UK: +44 1793 647200
Germany: +49 2166 134-0
E: EMEAsales@AFLglobal.com



PROJECT DESIGN

Route/technology/equipment/
special solutions



PROJECT MANAGEMENT

Turnkey/sub-contract



INSTALLATION



SUPPLY OF SERVICES AND EQUIPMENT

Passive/active



LONG TERM SUPPORT

Bespoke maintenance
or condition monitoring
packages



www.AFLglobal.com
UK: +44 1793 647200
Germany: +49 2166 134-0
E: EMEAsales@AFLglobal.com